

# Table of Contents

## Introduction

Acknowledgments . . . . .	i
Video Instructions and Glossary . . . . .	ii
<i>IDNR Division of Education</i> . . . . .	iii

## Lesson Plans

### UNIT 1

Trees at Work - Just Look! . . . . .	1
Take a Closer Look. . . . .	5
Dead and Alive . . . . .	9
A Little Help from Their Friends . . . . .	13

### UNIT 2

Where Does the Green Go? . . . . .	17
What Do Trees Do for Dinner? . . . . .	21
Bugs, Beavers, Birch Trees and Birds . . . . .	25

### UNIT 3

Trees for Tomorrow . . . . .	29
People Who Work in the Woods . . . . .	33
Let's Plant a Tree . . . . .	37

Glossary . . . . .	41
--------------------	----

## A Closer Look

Suggested Field Trip Sites. . . . .	43
Maple Mix-up Activity . . . . .	47
References . . . . .	49
The Who Tree . . . . .	50

# ACKNOWLEDGMENTS

Production of the original *Kids for Trees* conservation education kit represented a cooperative effort on behalf of a variety of public and private organizations. The financial contributions and technical support provided by the following organizations and individuals have made it possible for Illinois school children to have the opportunity to learn from *Kids for Trees*.

## Original Donations

University of Illinois - Department of Natural Resources and Environmental Sciences  
Illinois Forest Stewardship Committee  
Illinois Conservation Park and Recreation Foundation  
Illinois Power Company  
Illinois Conservation Police Officers Association  
Illinois State Nurserymen's Association  
WAL-MART Store #1420, Streamwood, Illinois

## Original Grant

U.S. Forest Service

### ***Kids for Trees* Planning Committee:**

Gary Rolfe, University of Illinois - Department of Natural Resources and Environmental Sciences  
T. J. Jacobs, University of Illinois - Department of Natural Resources and Environmental Sciences  
Glenda H. Burke, University of Illinois - Department of Natural Resources and Environmental Sciences  
Jim Smithson, Illinois Power Company  
Randy Vogel, Illinois Nurserymen's Association  
Dave Gillespie, Illinois Department of Natural Resources  
Stu Pequignot, Illinois Department of Natural Resources  
John Schwegman, Illinois Department of Natural Resources

### **External Education Review Panel:**

Louis Oberneufemann, Belle Valley Elementary, Belleville  
Karen O'Connor, The Chicago Academy of Sciences, Chicago  
Alexia Tryzna, Field Museum of Natural History, Chicago  
Karen Zuckermann, Hollis Grade School, Peoria

## Revisions

Revisions were made to the original text of the *Kids for Trees* education kit in 2002 by the following people. Their efforts to update the enclosed materials are greatly appreciated.

Kathy Andrews, Illinois Department of Natural Resources  
Irene Flebbe, Sand Ridge Nature Center, Forest Preserve District of Cook County, Illinois  
Faye Frankland, Illinois Department of Natural Resources  
Valerie Keener, Illinois Department of Natural Resources  
Dick Little, Illinois Department of Natural Resources (retired)  
Diane Murphy, University of Illinois, Forest Resource Center  
Don Powers, Western Illinois University  
Dan Schmoker, Illinois Department of Natural Resources  
Jenny Skufca, Illinois Department of Natural Resources

*Kids for Trees* was revised by Illinois Department of Natural Resources Division of Education staff in 2008, 2015 and 2020.

# KIDS FOR TREES VIDEO

The video accompanying this program is designed as an introduction to trees, tree products and the environmental benefits of trees and forests. The video is nine minutes long and may be shown before or after teaching Lesson Plan #1, Trees at Work...Just Look! Some words used in the video may need to be defined before viewing, depending on the grade level of your audience. Suggested Grade Level: K-3

Listed below are the words that we suggest you review as a spelling or a vocabulary lesson.

**Apatosaurus** - any of the four-legged, plant-eating dinosaurs

We saw the huge bones of an *Apatosaurus* at the museum today.

**carbon dioxide** - a gas absorbed from the air by a plant, which uses it to make food

Trees can help clean the air by using up some of the carbon dioxide.

**chlorophyll** - substance in plants that makes them green

Trees use chlorophyll, carbon dioxide and sunshine to make their own food.

**dinosaurs** - a large group of extinct reptiles that lived millions of years ago

Some types of dinosaurs were the largest animals that ever lived.

**environment** - the surrounding area in which an animal, plant or other organism lives

Our zoo tries to make each animal's cage like its natural environment.

**forest** - a large area covered with many trees and plants

We searched in the forest for mushrooms last spring.

**giant redwood** - a huge tree usually found in California

Some giant redwood trees grow to a height of more than 300 feet.

**ginkgo tree** - a showy tree, originally from China, with fan-shaped leaves and yellow fruit

We love to sit in the shade of our ginkgo tree in the summer.

**harvest** - to gather plants or animals for human use

Sometimes we harvest trees to make furniture and other wood products.

**mineral** - nonliving substance found in nature that is used by living things to grow

The roots of a tree can take up minerals and water from the ground.

**mulch** - a protective covering of material spread on the ground to enrich the soil, hold in water or keep the soil at a steady temperature

The gardener spread mulch around the sapling.

**noise pollution** - loud unwanted sounds that disrupt nature's sounds

Loud jet planes, cars and machines produce noise pollution.

**nursery** - a place where plants are grown for distribution to other places

We buy our garden plants and trees from the nursery.

**nutrient** - something needed by animals and plants for growth

Trees use nutrients they get from the soil much like humans use vitamins.

**oxygen** - a gas in the air which many living things need to survive

When a tree makes its own food, it gives off oxygen, which is needed by most living things.

**plant** - a many-celled organism that cannot move from one place to another on its own and that makes its own food

Every summer I help water the plants in our garden.

**renewable resources** - living parts of the environment that can renew or replace themselves

Renewable resources, like trees and grasses, can grow back even if they are cut.

**sap** - liquid carrying water and nutrients that flows through a tree

The sweet sap of a sugar maple tree is used to make maple syrup.

**seed** - the part of a plant from which a new plant can grow

We planted the seeds just last week, and we can already see sprouts.

**soil** - the top five feet of the ground in which plants grow

The soil around my house is very sandy.

# Illinois Department of Natural Resources Division of Education

The Illinois Department of Natural Resources' Division of Education is responsible for the development and dissemination of educational programs and materials and for training in their use.

**PROFESSIONAL DEVELOPMENT:** ENTICE (Environment and Nature Training Institute for Conservation Education) educator workshops; Professional Development Hours available

**SUPPLEMENTAL MATERIALS:** Illinois-specific posters, activity books and worksheets, many with English- and Spanish-language versions

**ITEMS FOR LOAN:** supplemental resources trunks available statewide

**GRANTS :** *Illinois Biodiversity Field Trip Grant* and *Schoolyard Habitat Action Grant*

**OTHER:** Web page; *Earth Day in the Parks*; Facebook; Kids for Conservation®; SMARTBoard™ lessons; video podcasts and more items!



Illinois Department of Natural Resources  
Division of Education

One Natural Resources Way  
Springfield, IL 62702-1271  
217-524-4126

[dnr.teachkids@illinois.gov](mailto:dnr.teachkids@illinois.gov)

<https://www2.illinois.gov/dnr/education/Pages/default.aspx>

Publications Order Form

<https://dnr2.illinois.gov/teachkids/>

Equal opportunity to participate in programs of the Illinois Department of Natural Resources (IDNR) and those funded by the U.S. Fish and Wildlife Service and other agencies is available to all individuals regardless of race, sex, national origin, disability, age, religion or other non-merit factors. If you believe you have been discriminated against, contact the funding source's civil rights office and/or the Equal Employment Opportunity Officer, IDNR, One Natural Resources Way, Springfield, IL 62702-1271; 217/785-0067; TTY 217/782-9175. *Kids for Trees* © 2015, Illinois Department of Natural Resources

**GRADE LEVEL:** PreK-1

**NEXT GENERATION SCIENCE STANDARDS:** K-ESS3-1, K-ESS3-3, K-LS1-1, 1-LS1-1

**ILLINOIS EARLY LEARNING STANDARDS:** 11.A.ECb, 11.A.ECd, 11.A.ECf, 11.A.ECg, 12.B.ECa, 12.B.ECb, 12.E.ECb

**SKILLS:** observing, gathering information, critical thinking, communication

**OBJECTIVE:** Students will learn that animals and the environment itself depend on the invisible work of trees.

# TEACHER'S GUIDE

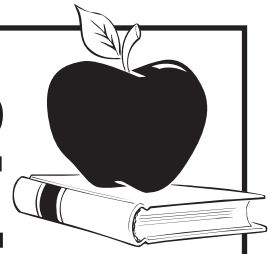

## UNIT ONE ■ LESSON ONE

# Trees at Work...Just Look!

### BACKGROUND

It may look like trees just stand around and do nothing. Actually, they are very busy doing a variety of jobs that are essential to animals and the environment.

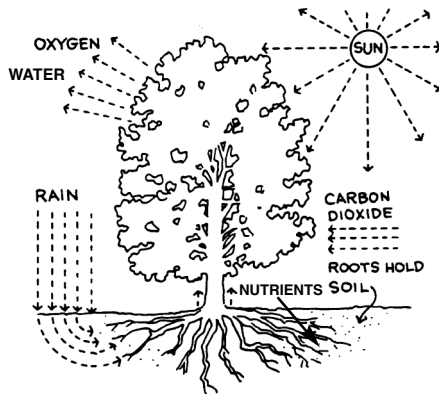

product that comes from trees. Every part of a tree is used to make some important product. Ground up wood is used to make paper for note pads, newspapers, candy wrappers and cereal boxes. Sap, the liquid that flows in trees, is used to make maple syrup, chewing gum, crayons, paint and soap. Bark is used to make dyes and medicines. Leaves and roots provide oils for cosmetics and medicines.

**Tree Houses.** Some animals spend most of their life in trees—many birds, for instance, as well as squirrels, raccoons, opossums and several types of insects. These animals are born in trees, live in trees and raise their young in trees. For these animals, trees provide shelter from the weather and from enemies. Trees provide food in the form of fruits, nuts, leaves, bark and roots. Even dead trees provide shelter and food for many species.

### What's a Tree Done for You Lately?

Very few people actually live in trees, but many of us live in wooden houses made from trees. Many of the items inside our homes are also made from wood, including furniture, floors, toys, musical instruments, kitchen utensils and much more.

In fact, there are many other household items, because wood is not the only

Just as important, trees provide jobs for people—foresters and nurserymen, for example. All of the products made from trees create many more jobs. Have you ever wondered who makes crayons or chewing gum?

Trees provide food for people, too. Fruits like apples, pears, peaches and cherries come from trees. So do nuts like walnuts and hazelnuts. Trees make our world a nicer place. Imagine your neighborhood without trees. Parks and campgrounds would certainly not be the same without trees. Trees are just beautiful to look at.

**Clean Air, Clean Water—Thank the Trees.** The quality of the world around us, the air, soil and water, depends on the roles trees play in our environment. Trees help cause rain because they return moisture to the atmosphere: their roots extract it from the soil and their leaves return it to the air. Trees clean the air we breathe because they take in carbon dioxide through their leaves and give off the oxygen we need to breathe. If trees didn't breathe, neither could we. Tree roots hold soil in place to prevent erosion which not only saves soil but also helps keep our streams and lakes cleaner. Water is much cleaner when there are lots of trees around. Trees provide shade in the summer to help keep our homes cool.

They block the wind in the winter which makes it easier to warm our homes.

## PROJECTS AND ACTIVITIES

Have students draw or collect from magazines pictures of animals that live in or around trees, along with corresponding pictures of food they might eat. Older students could compile two matching lists of animals and tree foods. Lists could be combined on the chalkboard as the basis for a participatory classroom matching exercise.

Have each student bring in or draw in class a picture of his or her favorite product that comes from a tree. You may want to discuss some foods that students would not suspect are tree products such as cinnamon (bark) and olives (fruit). Students could also provide pictures of the food in its natural state and as part of a finished product—apple pie or peach ice cream, for example.

Make a chalkboard list, elicited from students, of items that are made from trees. Don't overlook nonwood products such as crayons (from sap), cork (from bark) and suntan lotion (from cellulose). Discuss the parts of the tree that the products may have come from or the number of jobs that may have been required to produce the product. Have the students copy the list and take it home to survey their home for those and other wood products.

Explain that we make products from wood because it's strong, durable and easy to work with. Discuss with students useful things they could make with string and twigs or branches they find on the ground. Lead the students on a twig search, then actually construct some useful item or items (pencil holder, picture frame). Students could also do this individually or in groups. Have each student describe or draw his or her favorite place where trees grow, favorite tree or favorite activity involving trees.

Have students discuss or actually plan a project with trees that could improve the environment. Discuss how even an individual student could accomplish some part of this project.

Have a tree party where everyone eats tree snacks!

## EVALUATION

Why do people plant trees in their yards? Are there any places in the world without trees? What are they like? How are they different from where you live? Would you want to live there? Why? How do people depend on trees?

## EXTENSIONS

Divide the class into three groups. Individuals in the first group draw or collect pictures concerning the relationship between trees and wild animals. The second group focuses on trees and people. The third group is concerned with trees and the environment. When the pictures have been collected, the groups should assemble them into three poster-sized collages with titles of their choice.

Have individual students, or a group of students, pick a single tree and observe it closely for a period of time—fifteen minutes, for example. Students should then draw or compile a list of all of the evidence of animal activity that they found: actual activity involving birds, squirrels and other animals; observed nests; evidence of animals eating (holes in leaves, piles of sawdust, bare branches or empty fruit pods); and others.

Have students, as individuals or groups, create and answer their own "what if" questions. Examples might include: "What if birds didn't have trees; where would they live?"; "What if we didn't have wood; what would we make chairs from?"; or "What if there were no trees; what would be in parks?"

Construct a classroom terrarium (see "References," page 49, *Bottle Biology Resources Network*) with small treelike plants to demonstrate how trees return moisture to their environment. Add water, seal the terrarium, then have the classroom observe how the moisture is recycled.

## VOCABULARY

carbon dioxide  
environment  
erosion  
oxygen  
sap

# Trees at Work... Just Look!

# STUDENT'S GUIDE

## Tree Houses

Trees don't just stand around. They do many jobs that are very important to animals and the environment. Some animals spend most of their life in trees. Birds, squirrels, opossums, raccoons and insects find shelter from the weather and enemies in trees. They get their food from trees, too. Dead trees provide shelter and food for many animals.



## What Trees Do for You

Many people live in wooden houses. Many products in our houses are made from wood. Every part of the tree can be used to make something including paper, crayons and medicine. Trees provide jobs for people. Trees give us food. And trees make our world more beautiful.

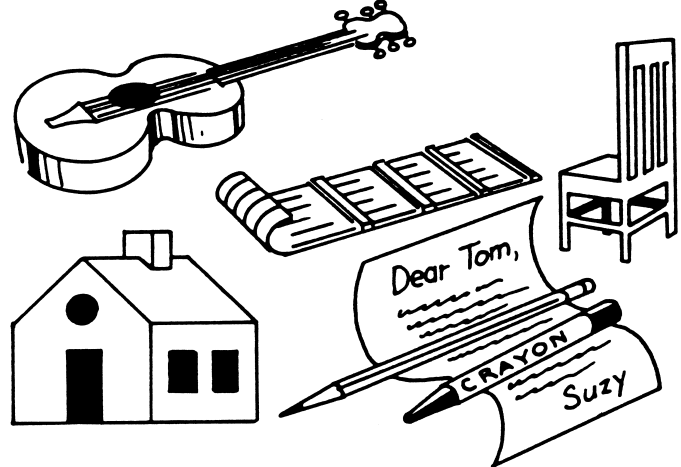
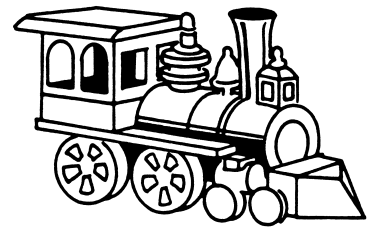

## Trees at Work Make a Better World

Trees help cause rain. Trees clean the air we breathe. Tree roots keep soil from washing away. Trees provide shade in the summer and block cold winds in the winter.

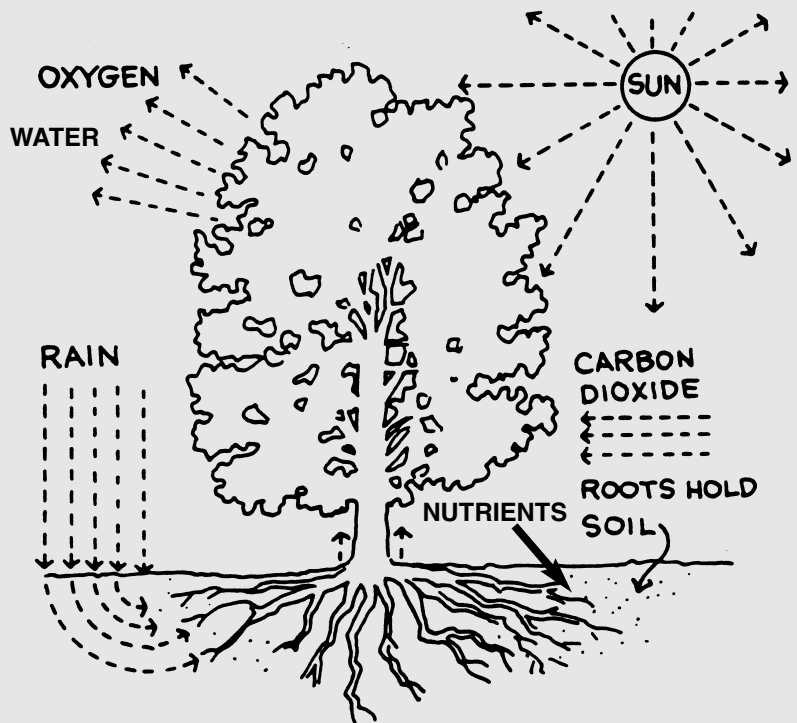

# Trees at Work

## What you will need

- heavy white construction paper
- scissors
- crayons or markers
- tape (optional)

1

Fold a piece of 9" x 12" construction paper into three panels, as shown.

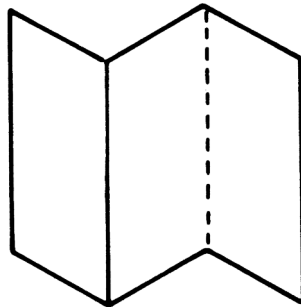

2

Unfold the paper so there are three trees. Decorate the trees to show they are important to animals and the environment. Your trees could show differences between seasons of the year.

2

Draw the tree shape on the front panel. Carefully cut out the shape.

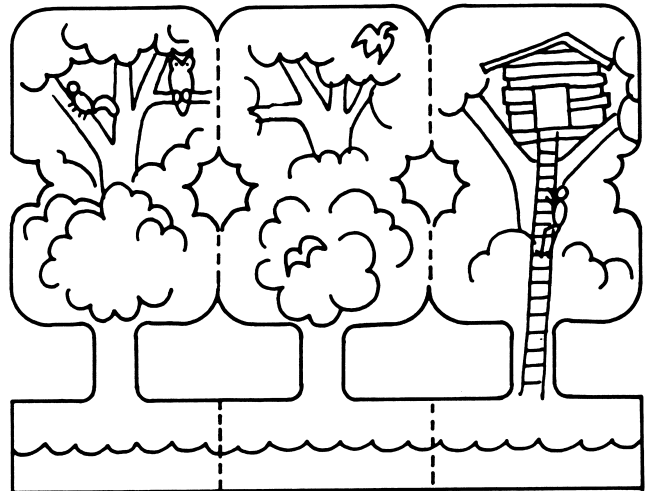
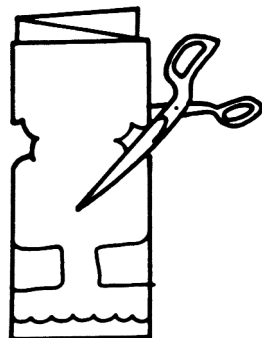

4

Make more than one set of trees and tape them together to make an entire forest.

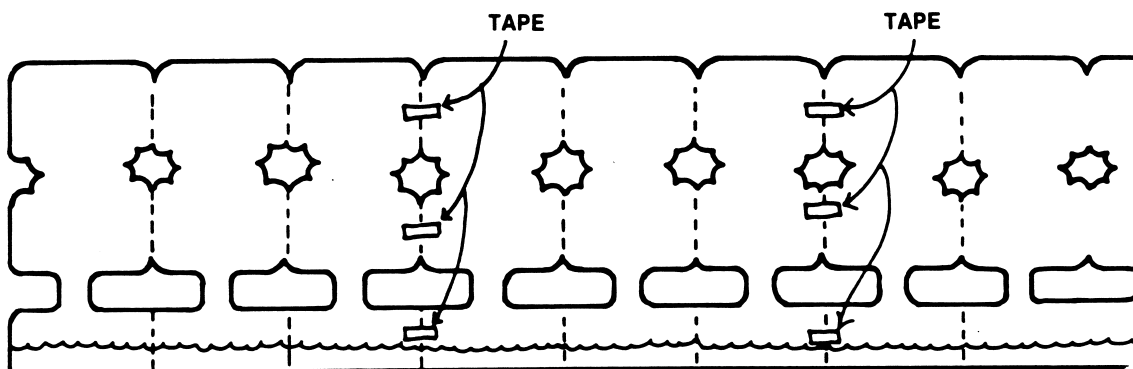



**GRADE LEVEL:** PreK, 1, 2

**NEXT GENERATION SCIENCE STANDARDS:** 1-LS1-1, 2-LS4-1

**ILLINOIS EARLY LEARNING STANDARDS:** 11.A.ECa, 11.A.ECb, 11.A.ECd, 11.A.ECf, 11.A.ECg, 12.A.ECa, 12.A.ECb, 12.B.ECb, 12.F.ECa

**SKILLS:** observing, finding information

**OBJECTIVE:** Students will learn that each type of tree has distinctive bark and unique leaves and that these characteristics can be used to determine the species of the tree.

# TEACHER'S GUIDE

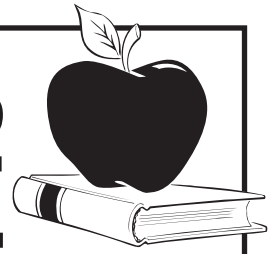

## UNIT ONE ■ LESSON TWO

# Take a Closer Look

### BACKGROUND

Most students have probably not carefully observed tree bark and are not aware that each tree has bark with distinctive characteristics. Similarly, they will not have observed the sometimes minor differences in leaves from different types of trees.

**Bark Basics.** From tree to tree, bark varies in a surprising number of ways. The differences can be very important for purposes of tree identification. What color is the bark? Does it feel rough or smooth? Is it plain or does it have a pattern? If it has a pattern, is the pattern arranged up and down, from side to side or both? Does it have an odor? Is it thick or thin? Is it loose or tight against the tree? A number of common trees can be readily identified by their bark alone, including sycamore, birch and shagbark hickory trees.



SHAGBARK

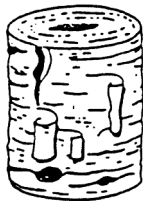

BIRCH

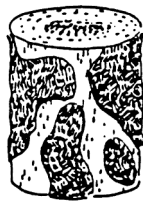

SYCAMORE

**Looking at Leaves.** Leaves come in an amazing variety of sizes and shapes—from the smallest pine needle (which is a leaf) to a large sycamore or

sweet gum leaf. In examining leaves it is interesting and important to note the variety of ways in which they can differ. Some ways, like size, are obvious. Others can only be detected by careful observation. Leaves can be smooth or hairy, shiny or dull. They can have pointed lobes or rounded lobes. The number of lobes can vary. They may have a sawtooth edge or a smooth edge. They may have one central vein with other veins leading off it. They may have several main veins which radiate from a single point at the base of the leaf. Leaves may grow individually (simple) or in clusters of leaflets (compound). They may grow across from each other on the branch (opposite) or not across from each other (alternate). Leaves come in virtually every shade of green—sometimes with other colors mixed in. All of these characteristics are important and interesting to explore.

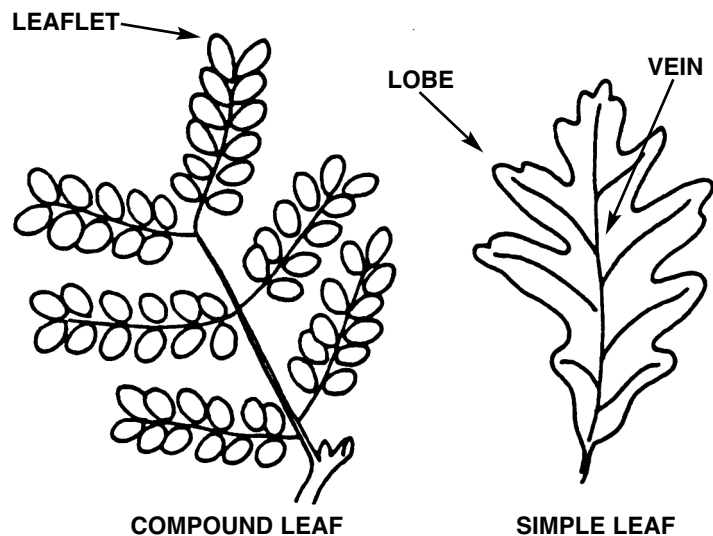

**Name That Tree.** There is at least one thing unique about the leaves of every individual type of tree. With just a single tree and a good tree identification book, you can identify most types of trees.

## PROJECTS AND ACTIVITIES

Take the class outside with paper (not too thick) and crayons (unwrapped so that the sides may be used). Make rubbings of bark patterns by holding or taping the paper tightly against a tree and rubbing with the side of the crayon. Make rubbings of as many types of trees as you can find. In the classroom, discuss and compare the different patterns. Can any of the trees be identified by their bark patterns?

Bring several pieces of bark to school along with pictures of the types of trees from which they came. Place the pieces of bark in separate boxes or paper bags so they cannot be seen. Can students match bark to tree pictures merely by feeling the bark pattern of the samples?

Ask the class: What color is tree bark? Collect and record the answers then take the class for a walk in the neighborhood. Find the colors that have been suggested. Then list all of the other colors you find. Ask students to draw a forest of trees and color the bark using all of the colors that you observed.

Have each student bring a leaf to class. Students should compare leaves to find classmates with matching leaves. Students with matching leaves should be grouped together and asked to identify their type of tree with the aid of a tree identification guide. Have students press the leaves. Repeat the exercise in a different season and have students compare leaves from different seasons.

A Year In the Life of a Tree. Locate a tree and observe it for an entire school year. Record changes on a weekly basis.

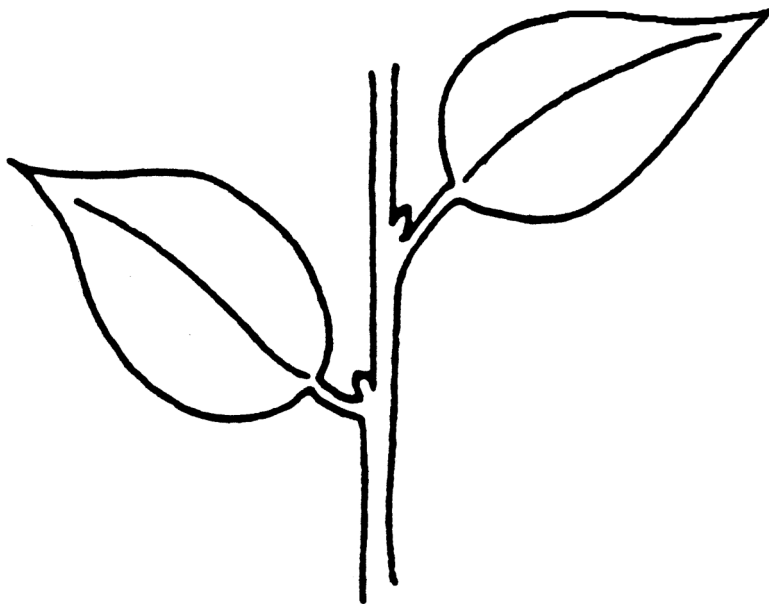

**ALTERNATE LEAVES**

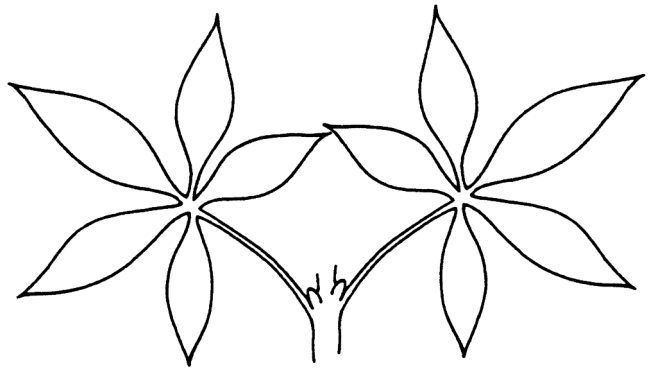

**OPPOSITE LEAVES**

Keep records of changes in leaf color. When leaves are gone, note any nests or animal activity. Note when buds first appear and when leaves emerge. Record leaf development.

## EVALUATIONS

Have each student bring a leaf to class. Ask each student to study his or her leaf carefully. Review with the class the features that distinguish individual leaves—the shape, the lobes, sawtooth edges, the pattern of veins. Ask students to very carefully observe these features, then put the leaf away and draw and color it from memory emphasizing as many features as possible.

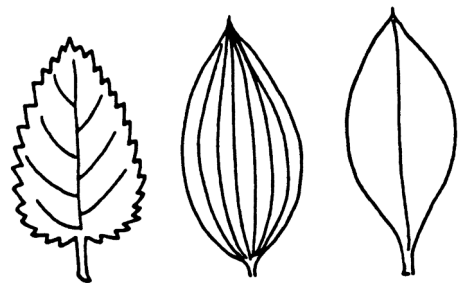

Younger students may be given a pile of different leaves to sort by shape. Then they count the number of piles of leaves.

## VOCABULARY

lobe  
vein

# Take a Closure Look

# STUDENT'S GUIDE

## Bark Basics

There are lots of kinds of bark. Look for the differences. What color is the bark? Is it rough or smooth? Is it thick or thin? Does it have a smell? What other differences can you find?

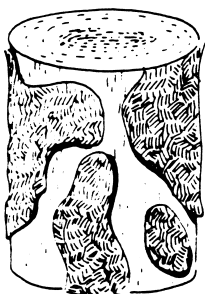
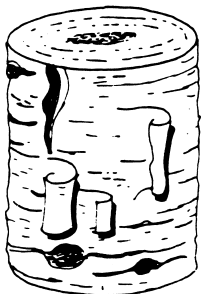
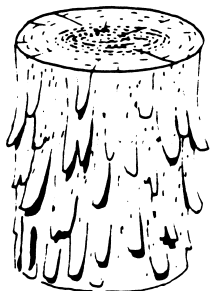
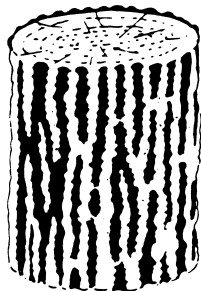

## Looking at Leaves

Leaves have lots of different sizes and shapes. A tiny pine needle is really a leaf. How many pine needles would fit on a maple leaf? Find a leaf and look at it closely. Is it smooth or hairy? Is it shiny or dull? Does it have one point or lots of points? Are the points sharp or round? Is it simple or compound? Can you find the veins in your leaf? What other interesting things do you see?

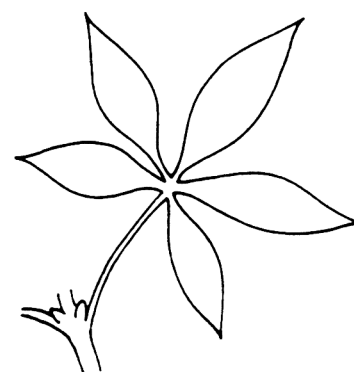
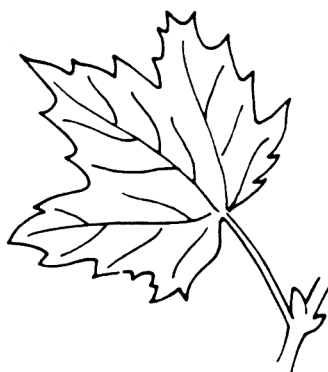
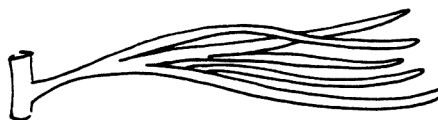
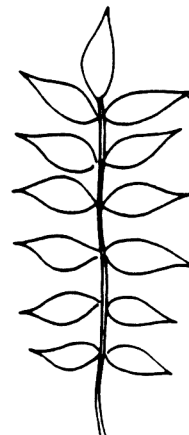
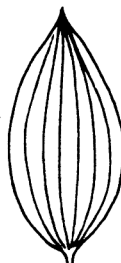
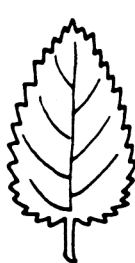

## Name That Tree

Learn the name of your leaf. That's the name of the tree. Leaves are the easiest way to tell trees apart.

# Let's Make a Tree!

## What you will need

- construction paper
- a large piece of white paper, at least 11" x 25"
- scissors
- crayons or markers
- yarn
- glue
- transparent tape
- an empty toilet paper tube

You can make a beautiful three-dimensional tree picture.

1

To make the trunk, cut a toilet paper tube in half lengthwise. Both halves should be the same size.



2

Color both pieces of the tube to look like bark.

3

Tape both pieces of the trunk, end to end, in the center of a large piece of white paper. Leave plenty of room at the top for leaves and plenty of room at the bottom for roots.

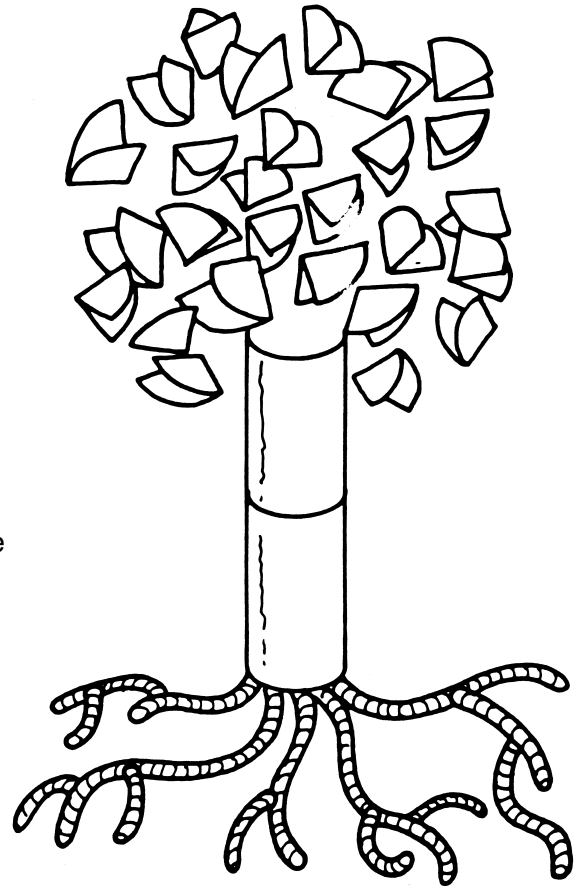

4

Cut your leaves from colored construction paper. Cut a folded half circle shape as shown in the picture and glue one of the halves to the white paper to form the shape of the branches and leaves of the tree.

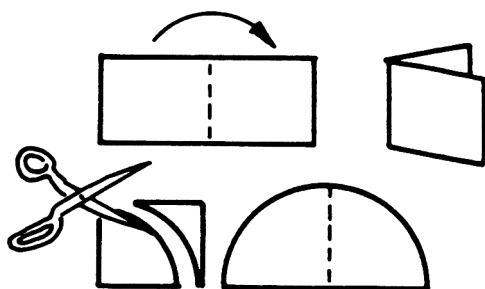

5

Make roots by cutting pieces of yarn in different lengths. Glue them under the trunk. Be sure to spread them out like real roots.

6

Finish your picture by drawing in more trees, shrubs and animals.

**GRADE LEVEL:** PreK

**ILLINOIS EARLY LEARNING STANDARDS:** 11.A.ECa, 11.A.ECb, 11.A.ECf, 11.A.ECg

**SKILLS:** observation, critical thinking, library research

**OBJECTIVE:** Students will learn how “dead” trees are actually alive with activity and return nutrients to the soil.

# TEACHER'S GUIDE

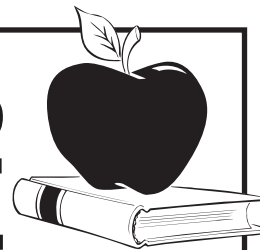

## UNIT ONE ■ LESSON THREE

# Dead and Alive

### BACKGROUND

A dead tree may look lifeless, but actually it is teeming with activity—the activity of live animals. Dead trees have features that live trees do not—features that attract more than 85 species of animals in Illinois.

**Bugs Love Them.** Many species of insects and other invertebrates (animals without backbones) feed on and live in dead trees. They bore holes in these trees to build their nests. These tiny animals provide food for many other larger animals. But that's just the beginning of the story.

**So Do Birds.** Many birds, especially woodpeckers, love to feed on the insects that live in dead trees. These birds feed on insects by enlarging holes that insects have bored. They eat the insects and sometimes make the holes so large that they move into them themselves. When they leave the holes, other animals move in, including squirrels, raccoons, opossums and wood ducks. Lots of other birds may live in dead trees or at least use them. Owls, hawks and flycatchers, for instance, perch in dead trees looking for prey to eat (mice, insects and small birds). They have a very good view because there are no leaves to block their vision.

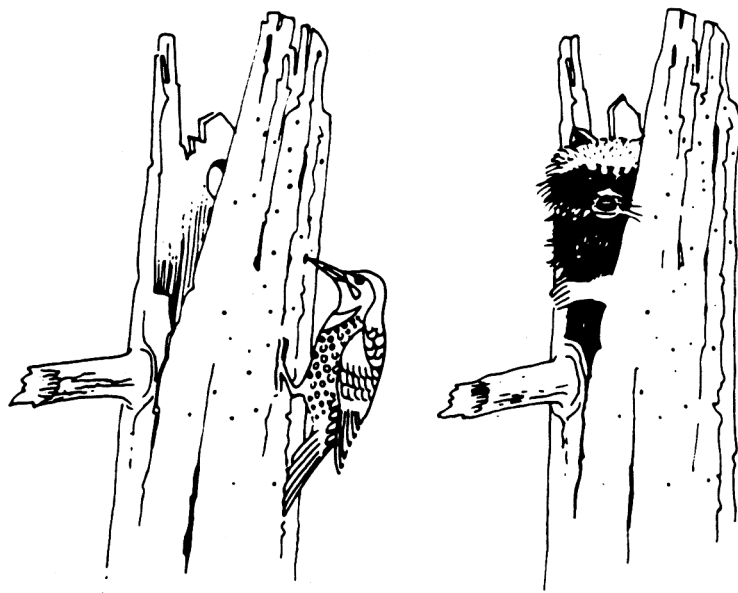

**Home Sweet Home.** When limbs fall off trees they make brush piles on the ground. These piles provide homes for many animals. Insects move right in. And so do the animals that eat insects, including skunks, lizards, birds and many others. Rabbits don't eat insects, but they are quite comfortable living in the shelter of brush piles.



### When Fish Live in Trees.

When trees that live on the edge of lakes or streams die they drop their branches into the water. Eventually, the tree may fall into the water. These branches and trees make excellent places for small fish to hide, a place where many fish raise their young and a very good hunting ground for larger fish.

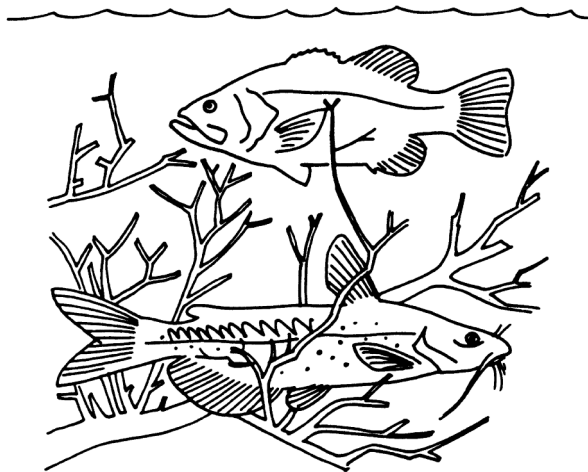

In stories, dead trees are often portrayed as scary. Find a picture of a dead tree in a story book and discuss how it is portrayed. Have the class create a scary story involving a dead tree. Students must be able to explain any scary happenings with natural causes. Snakes, for instance, might be around dead trees to catch mice.

### How Old Trees Become New

**Trees.** Eventually, dead trees fall down. Insects, other animals and bacteria continue to live in them as they decay. On the ground a dead hollow tree might become a home for rabbits or a den for foxes. Finally the tree decays completely and returns its nutrients to the soil. Good soil is made up of plants that have died and rotted, becoming organic matter. Succession is the natural process of change on a site from one form of vegetation to another. Dead trees live on as part of other organisms that take up the nutrients from the soil and pass them through the food chain.

## PROJECTS AND ACTIVITIES

Write each of these animal names on an index card and distribute them to your students: squirrel, raccoon, hawk, opossum, bluebird, black snake, owl, bat, woodpecker, treefrog, wood duck, beetle, mouse, flying squirrel. Have pictures of the animals on the bulletin board. You may wish to utilize the Species Search pages (<https://www2.illinois.gov/dnr/education/Pages/Biodiversity-of-Illinois.aspx>), Illinois Department of Natural Resources' Trading Cards or Internet sites to find photographs of the species. Each of these animals uses dead trees. Ask your students to imagine ways that these animals might find a dead tree useful. Students might be assigned an animal and asked to draw or find a picture of it. Pictures could be collected and pasted onto a poster-sized diagram of a dead tree. Features like holes and nests should be added.

Ask students where the leaves that fall to the ground in autumn have gone by spring. Explain that dead trees eventually lose their branches and fall down, returning to the soil nutrients for other trees and plants. Discuss with students how this same principle is used by people who return their grass clippings to the lawn, make compost piles or turn their garden under in the fall. Visit the perimeters of the school yard to find evidence of plant material that is decaying and returning to the soil. Is there evidence of insect activity in this decaying material?

Owls at night make ghostlike sounds. Bats may live under loose sections of bark. White trunks and branches might look like skeletons in the moonlight. Go outside and look for dead trees and branches and any animals living in them.

## EVALUATION

Have students draw a picture with the title "What Good Is a Dead Tree?." The picture should show as many ways as students can think of that dead trees are useful. Ask the students, "Do fish live in trees?" Did any students include fish in their pictures?

## EXTENSION

As a class project, make a mini compost pile in a suitable container such as a three-pound coffee can with ventilation holes or two-liter plastic beverage bottle (see "References," page 49, *Bottle Biology Resources Network*). Add dead leaves and small twigs during the school year, stirring frequently. Measure and keep a record of the amount of decomposition that takes place each month. Have older students calculate the rate of decomposition. At the end of the school year, make a special short field trip to a young tree and fertilize it with this compost.

## VOCABULARY

bore	nutrient
decay	succession
invertebrate	

# Dead and Alive

# STUDENT'S GUIDE

Even when a tree is dead, it is full of life.

## Bugs Love Them

Many kinds of bugs love dead trees. They eat the wood and build their homes in them.

## So Do Birds

Some birds love to eat the bugs that live in dead trees. Birds make big holes in dead trees and move right in. Birds that hunt like dead trees. There are no leaves so they have a good view.

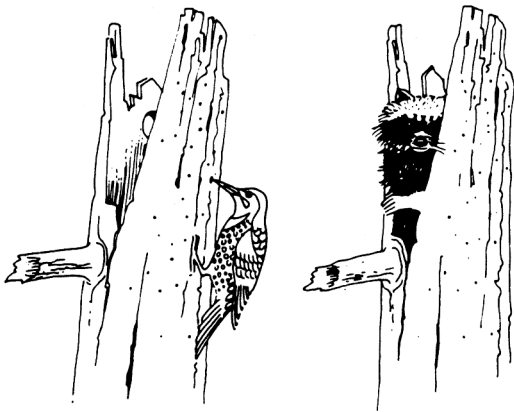

## Home Sweet Home

When limbs fall on the ground, animals make homes in them.

## When Fish Live in Trees

When limbs or trees fall in the water, they make homes for fish.

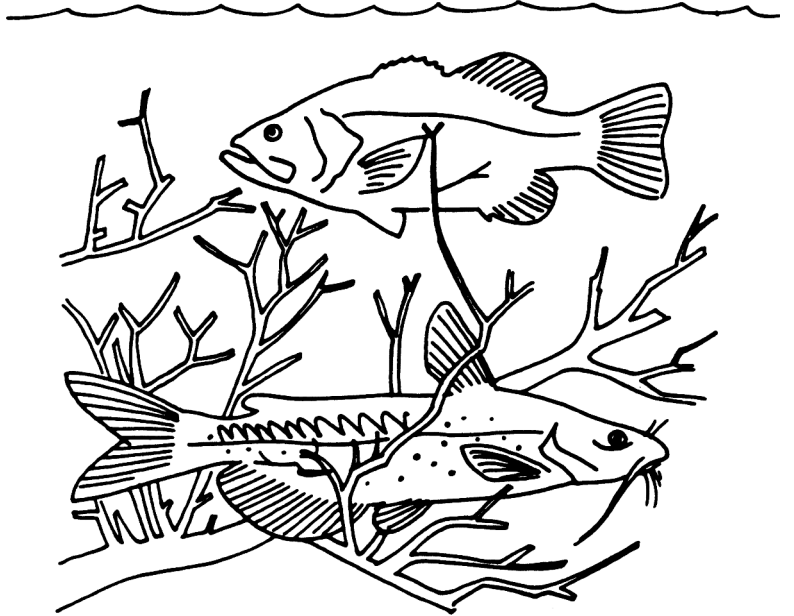

## How Old Trees Become New Trees

After dead trees fall down, they become part of the soil. Soon there is no more tree. But there is very good soil for new trees to grow in because the soil is rich with organic matter.

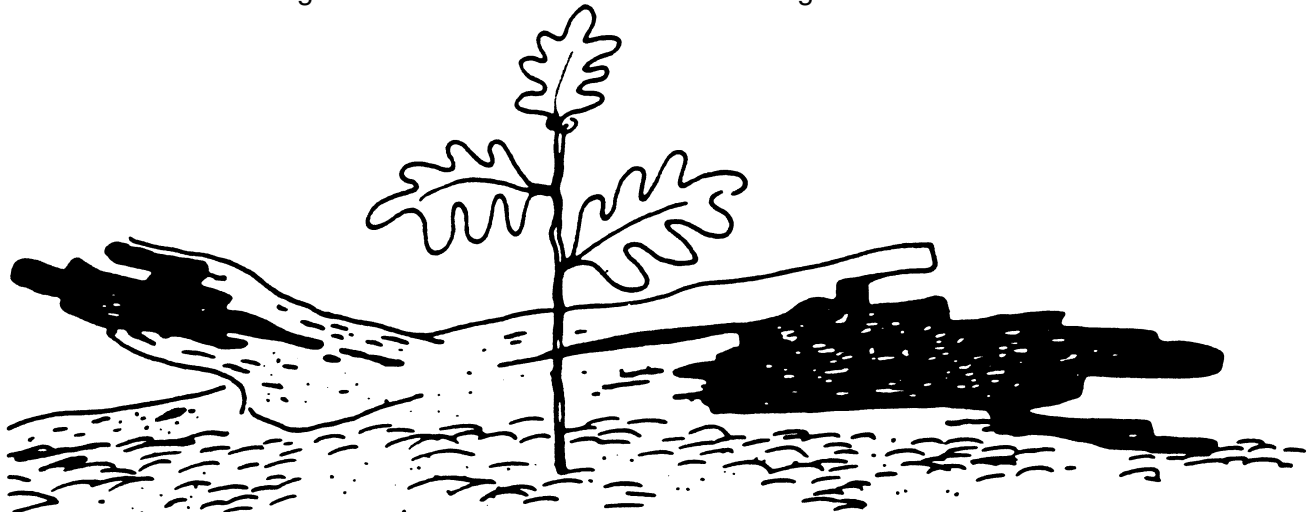





**GRADE LEVEL:** PreK

**ILLINOIS EARLY LEARNING STANDARDS:** 11.A.ECa, 11.A.ECd, 11.A.ECf, 11.A.ECg, 12.A.ECa, 12.B.ECa, 12.C.ECa, 12.D.ECa, 12.D.ECb

**SKILLS:** observing, gathering information, critical thinking, communication

**OBJECTIVE:** Students will learn that animals and the environment itself depend on the invisible work of trees.

# TEACHER'S GUIDE

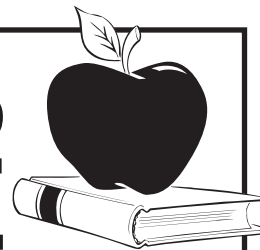

## UNIT ONE ■ LESSON FOUR

# A Little Help from Their Friends

### BACKGROUND

Trees can't move; they can only stand in one place. And yet they must move their seeds from place to place. If seeds just fell to the ground under the tree, they could not grow. There would not be enough light or water. The parent tree takes up too much room. But tree seeds don't just fall to the ground. They are moved to new locations in a number of ways.

**Blowing in the Wind.** Some tree seeds simply blow in the wind to new locations. Cottonwood trees, for instance, wrap their seeds in fluffy cottonlike material that easily blows great distances. Silver maple trees have seeds with wings on them like little helicopters. They twirl through the air and land some distance from the parent tree.

Other trees, willows for example, grow along stream banks. They may drop their seeds into the water so they are carried and planted downstream.

**Animal Planters.** Some seeds don't need the wind to fly. They just hitch a ride with a bird. Many trees, especially fruit trees, are planted by birds. The seeds of these plants are inside their fruit. Birds pick the fruit, fly away to eat

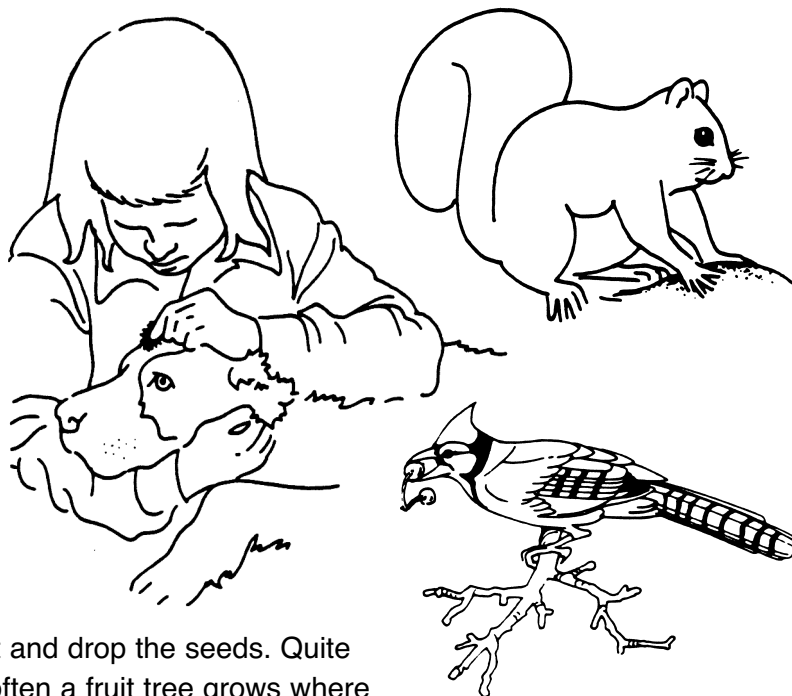

it and drop the seeds. Quite often a fruit tree grows where a seed has been dropped by a bird.

Squirrels are very important tree planters. Squirrels hide food away for the winter, especially acorns, walnuts and hickory nuts. Squirrels bury so many nuts that they don't find where they buried them. Inside every nut is a tree seed which, thanks to a squirrel, can become a full-sized tree.

Other animals plant seeds, too. Plant seeds can cling to the fur of a dog, a fox or a raccoon, only to fall off and grow in some distant location.

**How We Plant Trees.** People plant trees but not always on purpose. In nurseries, trees are started from seed in trays in greenhouses or outdoors in seed beds. Around our homes we usually plant trees once they have become healthy young

saplings. But people also plant trees accidentally. Like animals they may carry plant seeds that cling to their clothing. Like birds, people eat fruit and may leave the seeds behind to grow. Every student has probably picked up an acorn, an apple, a walnut, a buckeye or a pine cone and carried it to a new location. He or she may have planted a tree and not even known it.

## PROJECTS AND ACTIVITIES

Inside every seed is a complete plant ready to grow. This is easy to demonstrate to the class with lima beans. Soak some dried lima beans overnight then peel off the seed coat. Have students gently open them. A curled plant can be seen inside, ready to emerge.

Plant some trees right in the classroom. Have students bring in tree seeds, nearly any kind, from maple seeds to apple seeds, to avocado or peach pits, will do. Plant them in small flower pots. Put a layer of pebbles in the bottom of the pot covered with about three inches of tamped soil. Add a seed and cover it loosely with soil. If you use potting soil, mix it half and half with sand. Water the soil and label the pot. Water again only when the soil becomes dry. Keep a piece of plastic over the top of the pot until the seed emerges. Keep the pots in a warm, sunny location. The plants that emerge can grow into full-sized trees.

Using a good guide to tree identification (see "References," page 49), take a neighborhood nature hike in late spring and identify as many tree seeds as possible. Be sure to check the tree as well as the ground around it. If you encounter a flowering tree, point out that the seeds are developing in the flowers. In the fall, bring as many seeds as possible back to class, identify them with an identification book, and discuss how they might be dispersed naturally.



As a class, read *Johnny Appleseed* by Steve Kellogg. The story provides excellent discussion points not only on planting trees, but also on the environment and the relationship between people and nature.

Using a collection of seeds (walnut, pecan, acorn, etc.), place each seed in a sock and ask the students to reach inside the sock and identify the seed by its size and texture.

Divide the class into small groups. Give each group of students a variety of seeds. Have the students come up with a classification system for the seeds. They may choose to sort them by size, shape or method of dispersal. Have the students discuss how they made their decisions about how and in which group to classify the seeds.

## EVALUATION

Present students with a variety of tree seeds, either actual seeds or pictures, and have them describe as many ways as they can think of that each particular seed might be dispersed from the parent tree. Creative possibilities should be encouraged.

## EXTENSION

Take a field trip to a nursery where trees are started from seeds or cuttings in a greenhouse or in an outdoor seed bed, transferred to fields, and balled and burlapped for replanting. Also have students view the different types and sizes of trees at the nursery. Take a field trip to a nature preserve or wooded park and observe the distribution of the different types of trees. Discuss how these trees may have been planted: by people, by animals, by birds or by the wind or water.

## VOCABULARY

fruit	sapling
nursery	seed
nut	

# A Little Help from Their Friends

# STUDENT'S GUIDE

Trees can't move. They can only stand in one place. But trees have friends that help them move their seeds to good growing locations.

## Blowing in the Wind

Some seeds are carried by the wind. Cottonwood seeds can blow many miles. Maple seeds twirl like helicopters in the wind. Some seeds, such as those of the willow tree, float like little boats. New trees grow along the shore.

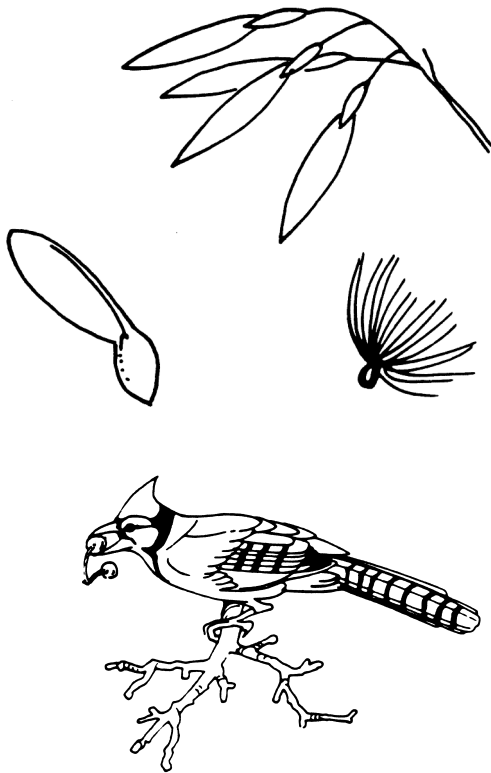

## Animal Planters

Some seeds are carried by birds. Birds plant cherry trees when they eat the fruit and drop the seed in their wastes.

Squirrels plant trees when they bury nuts and don't dig them up. Furry animals can carry some sticky plant seeds to new places.

## How We Plant Trees

People plant trees on purpose in their yards. Sometimes people plant seeds and don't even know it. Have you ever carried an apple core to a new place and left it on the ground? You may have planted a tree!

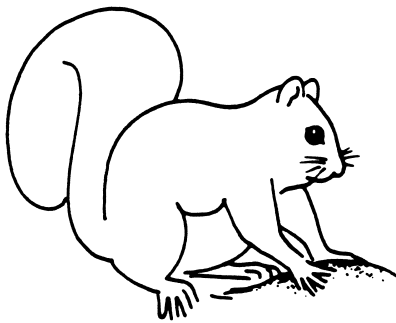

# Who Will Plant This Tree?

Here are six tree seeds/seedling and six tree planters. Draw a line from each seed/seedling to the most likely planter.



MAPLE



SEEDLING

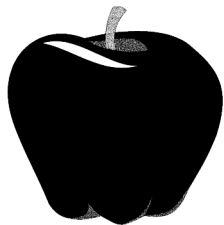

APPLE



OAK

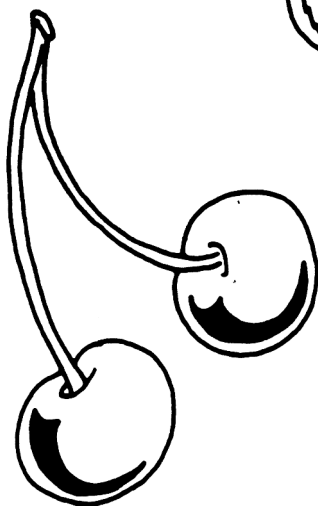

CHERRY



WILLOW

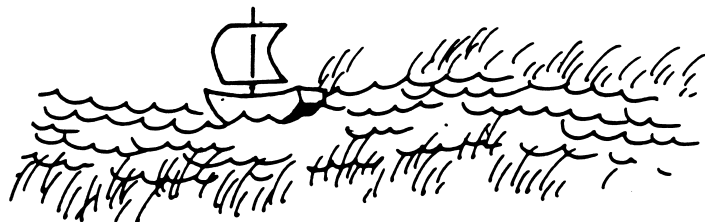
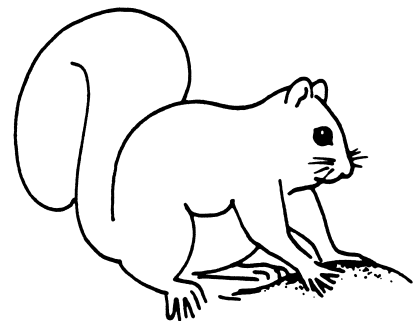
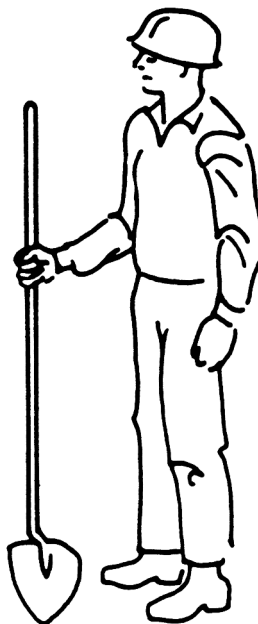
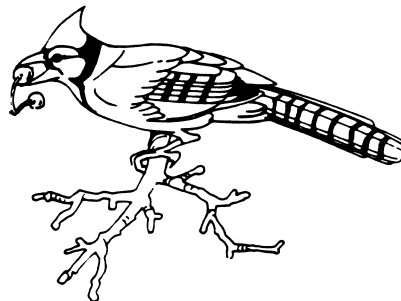
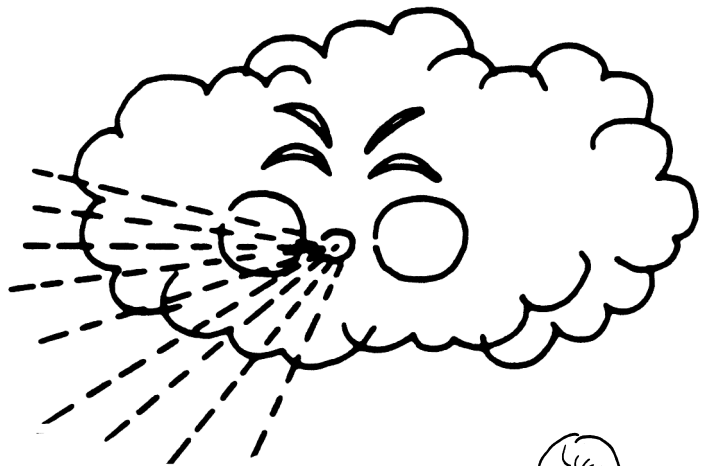

**GRADE LEVEL:** PreK, 2

**NEXT GENERATION SCIENCE STANDARDS:** 2-LS4-1

**ILLINOIS EARLY LEARNING STANDARDS:** 11.A.ECa, 11.A.ECb, 11.A.ECd, 11.A.ECe, 11.A.ECf, 11.A.ECg, 12.A.ECa, 12.A.ECb, 12.B.ECb, 12.C.ECa, 12.F.ECa

**SKILLS:** observing, gathering information

**OBJECTIVE:** Students will learn that leaves lose their green color as the days grow shorter and the weather becomes colder and that other colors become visible, while still other new colors are created.

# TEACHER'S GUIDE

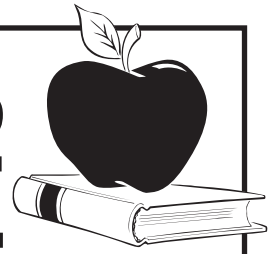

## UNIT TWO ■ LESSON ONE

# Where Does the Green Go?

### BACKGROUND

Leaves change color in the fall because the days grow shorter with fewer hours of sunlight.

When there's not enough sunlight, the green chlorophyll cells in plants stop making food and break down. As they break down, chlorophyll cells lose their green color, but other colors that have been in the leaf all along then can be seen. Still other new colors are formed through new chemical reactions that become possible once the chlorophyll is gone.

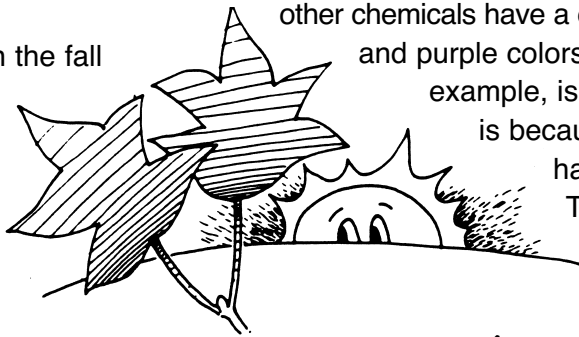

other chemicals have a chance to react with sunlight. Bright red and purple colors are the result. The sugar maple, for example, is one of the most colorful fall trees. This is because the leaves are full of sugars that have been produced by the chlorophyll. The sugars react to the sunlight and to the cooler weather by turning bright colors.

**When the Little Green Food Factories Shut Down.** All leaves have some yellow pigment in them, and many have red tones as well. But these colors can't be seen in the spring and summer because they are overpowered by the green color of chlorophyll. Chlorophyll cells need sunlight to do their job. Once there is not enough light, leaves stop producing food and lose their green color. Then the other colors can be seen. Leaves become yellow or red-brown.

Many of the brightest fall colors have not been present all along. They are made once the chlorophyll is gone. Now

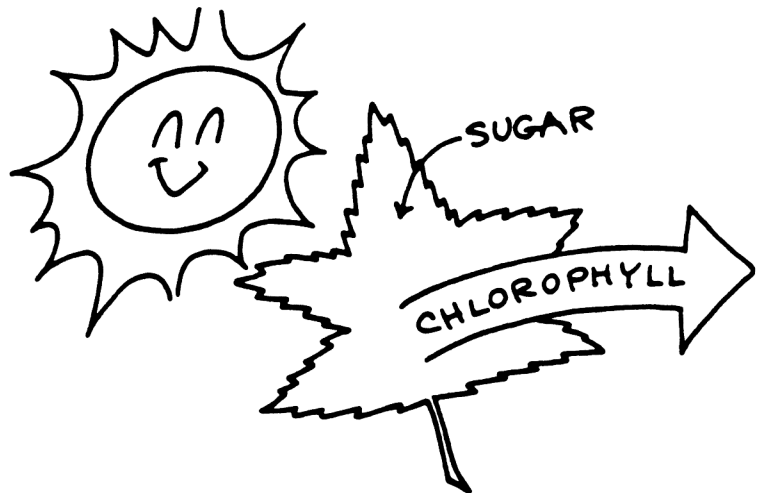

**The Best and the Brightest.** All leaves change color before they fall from the tree. But some leaves are more colorful than others. Just as some people's hair changes color as they get older, some leaves can only change to yellow or green. Weather conditions are another factor that affects the color of fall leaves. The best and the brightest colors occur in years that have wet summers, cool fall nights and warm, sunny fall days.

In Illinois, the best and the brightest fall trees are sugar maples, red oaks, ashes, sweet gum and sassafras trees.



SPRING



SUMMER



FALL

## PROJECTS AND ACTIVITIES

At the beginning of the school year have each student bring in a leaf from the tree of his or her choice. Have students press the leaves between newspaper sheets and then mount them on a piece of paper, preferably under clear adhesive plastic, leaving room for a companion leaf. In the fall, after the leaves have changed, have each student bring in a leaf from the same tree. Press and mount alongside the original leaf and have the class discuss the variety of colors represented or write a poem about the changes that have occurred.

Using watercolors, you can show how the green chlorophyll pigment in leaves can hide other colors. Start with yellow and cover it with green.

What happens? Start with red and cover that with green. Again, what happens? Now discuss what would happen if the green were removed. This can also be done with colored acetate swatches and an overhead projector.

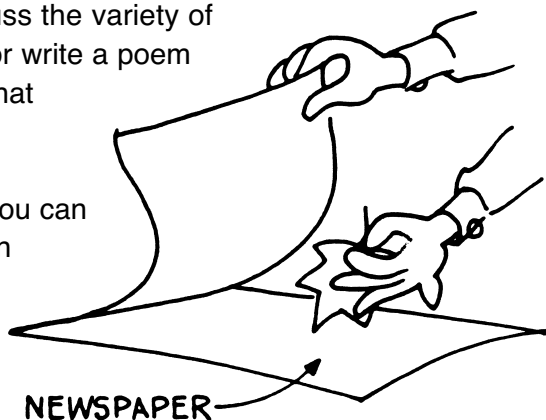

Have children bring to class pictures from magazines that depict colorful fall scenes. Compare the pictures. Are the colors the same? Why are they different? Are they from different localities, different types of trees? Can students determine, with a good tree identification book, which trees are pictured?

Make a chlorophyll leaf print. Place a leaf on the right half of a piece of white, cotton cloth. Fold the left half of the cloth over the leaf (to cover it). Place a piece of waxed paper under the cloth and another piece of waxed paper on top of the cloth. Use a hammer to pound the leaf. Be sure to do this on a hard surface that will not be damaged by the pounding. Wear safety glasses when you are pounding. The pounding brings out the

chlorophyll and leaves a green impression of the leaf. Make prints of several kinds of leaves and discuss the different shapes, colors and details.

Take the class on a brief neighborhood color walk. Have younger children identify colors. Older children may make a list of different colors that can be seen and tabulate the number of times each color is viewed.

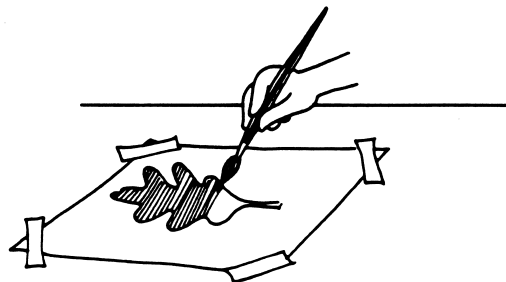

Have students bring in the most interesting leaf shape they can find. Trace it on graph paper. Count the squares covered by the leaf shape to determine the area, or size, of the leaf. (If a square is more than half covered, it is counted. If a square is less than half covered, it is not counted.) Color the outline in the leaf's summer colors or in its fall colors. Paste a selection of these leaves on one crazy tree poster or make a collage of interesting colors and shapes. Cut leaf tracings in half and have children match shapes.

## EVALUATION

Divide the class into small groups. Each group should discuss and arrive at an answer to this question: If leaves fall off in the autumn, why do they come back in the spring?

## VOCABULARY

cells  
chemical reaction  
chemicals  
chlorophyll  
pigment

# Where Does The Green Go?

# STUDENT'S GUIDE

The days are short in the fall, and the sun is low in the sky. There is not enough sunlight for leaves to make food.

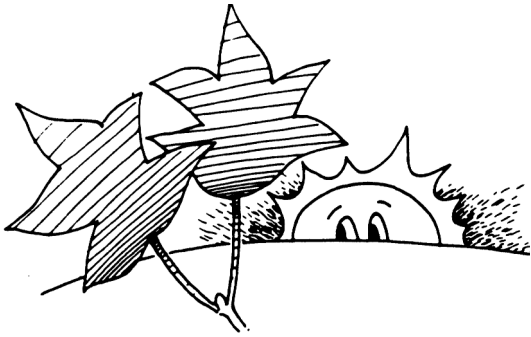

## Little Green Food Factories Shut Down

When leaves stop making food, they lose their green color. Then you can see other colors that have been there all along. You can see yellow, brown and red.



SUMMER

DARK GREEN



FALL

YELLOW

RED

BROWN

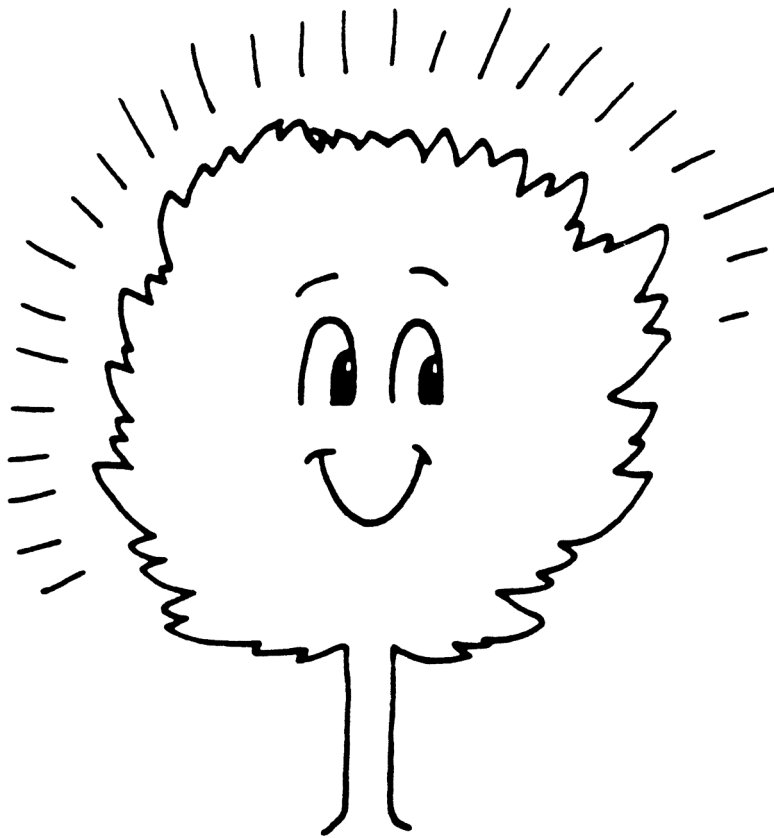

SUGAR MAPLE

## The Best and the Brightest

Some leaves make new colors when the green is gone. They make bright red and purple. Maple leaves make the brightest colors.

# When the Green Goes

## What you will need

- red, orange and yellow crayons
- green tempera paint, slightly thinned with water
- plastic spoon or other tool for scratching off the paint
- paper towels and water for clean up

When the green fades from leaves in the fall, you can see other colors that have been there all along. See for yourself how the green covers the other colors.

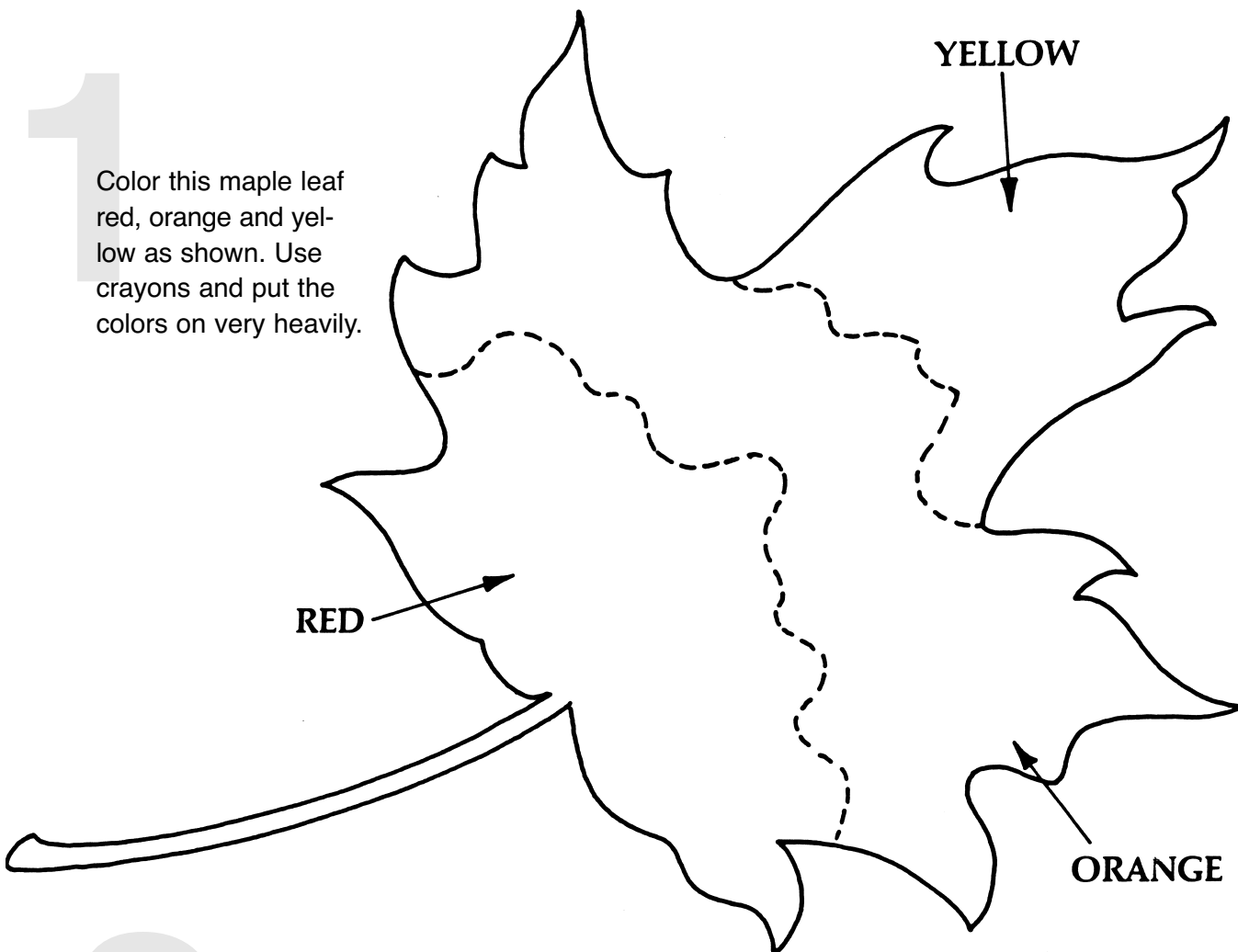

2

Now carefully paint over your colored leaf with green tempera paint. When all the other colors are covered, let the paint dry.

3

You can scratch off the green with a plastic spoon—or even your fingernail. Scratch any pattern you like—and see what happens when the green goes.



**GRADE LEVEL:** PreK, K

**NEXT GENERATION SCIENCE STANDARDS:** K-ESS3-1, K-LS1-1

**ILLINOIS EARLY LEARNING STANDARDS:** 11.A.ECa, 11.A.ECb, 11.A.ECd, 11.A.ECe, 11.A.ECf, 11.A.ECg, 12.B.ECa, 12.B.ECb, 13.B.ECb

**SKILLS:** observing, critical thinking, counting

**OBJECTIVE:** Students will learn how trees produce their own food and how every part of the tree contributes to the process of making and distributing food.

# TEACHER'S GUIDE

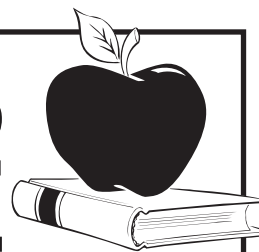

## UNIT TWO ■ LESSON TWO

# What Do Trees Do for Dinner?

### BACKGROUND

Trees require food, just like animals. They produce and distribute their own food in a special way.

#### Little Green Food

**Factories.** The food that trees need is made in the leaves. Each leaf contains millions of cells with chlorophyll, a green pigment. Chlorophyll cells are green, which is why leaves are green in the spring and summer. These cells actually make food through a process called photosynthesis. Chlorophyll cells take in carbon dioxide from the air. Chlorophyll cells combine this carbon dioxide with water sent up from the roots of the tree. In the chlorophyll cell, sunlight passes through this mixture and turns it into sugar and oxygen. The sugar is the food that trees need to grow. Oxygen is released into the air that we breathe.

**Pipelines Inside Pipelines.** Inside the trunk of the tree is a two-way pipeline. Just inside the bark there is a pipeline that the leaves use to send food down to the roots. This pipeline is called phloem (flo-em). Next to the phloem towards the middle of the tree is another pipeline—this one is called xylem (zi-lem)—that sends water up

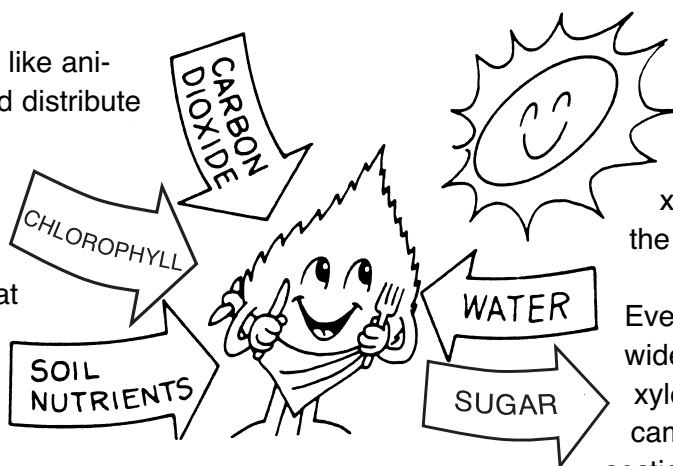

from the roots to the leaves. Between the phloem and the xylem there is an area of wood called the cambium. The phloem, cambium and xylem are the living portions of the trunk of a tree.

Every year the tree trunk becomes wider as new layers of phloem and xylem grow from the sides of the cambium. When you look at a cut section of a log you can see the

rings of new wood that are added each year the tree lives. In the center of the trunk of a tree is the heartwood. This portion of the tree is old phloem, cambium and xylem layers that are nonliving. The heartwood is very hard and gives a tree the strength to stand straight and tall.

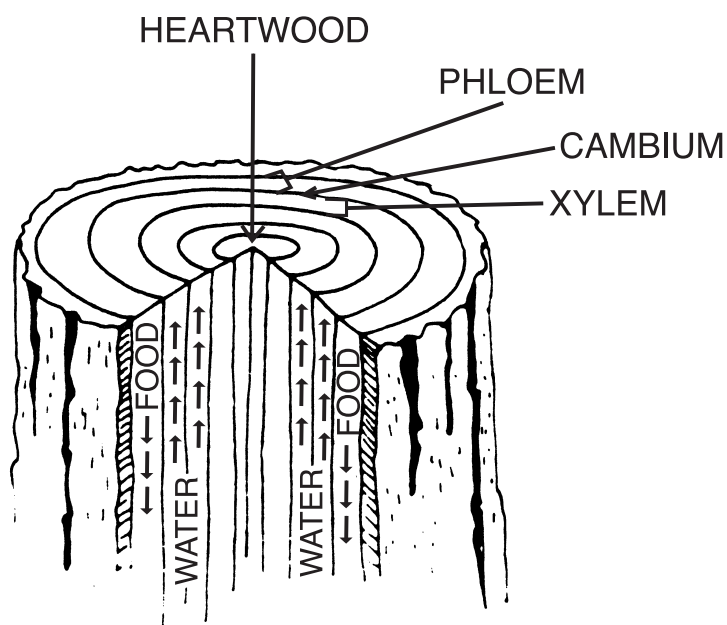

### At the Root of the System.

Underground, under every tree, there is a root system that extends two to four times further than the branches of the tree. In some trees the root system spread may be twice the height of the tree.

Attached to every root are tiny root hairs which have beneficial fungi growing on and in them (mycorrhizae). They act like miniature straws to draw up water and nutrients. That mixture is sent up the pipeline to the leaves. Roots also receive food from the pipeline so they can grow.

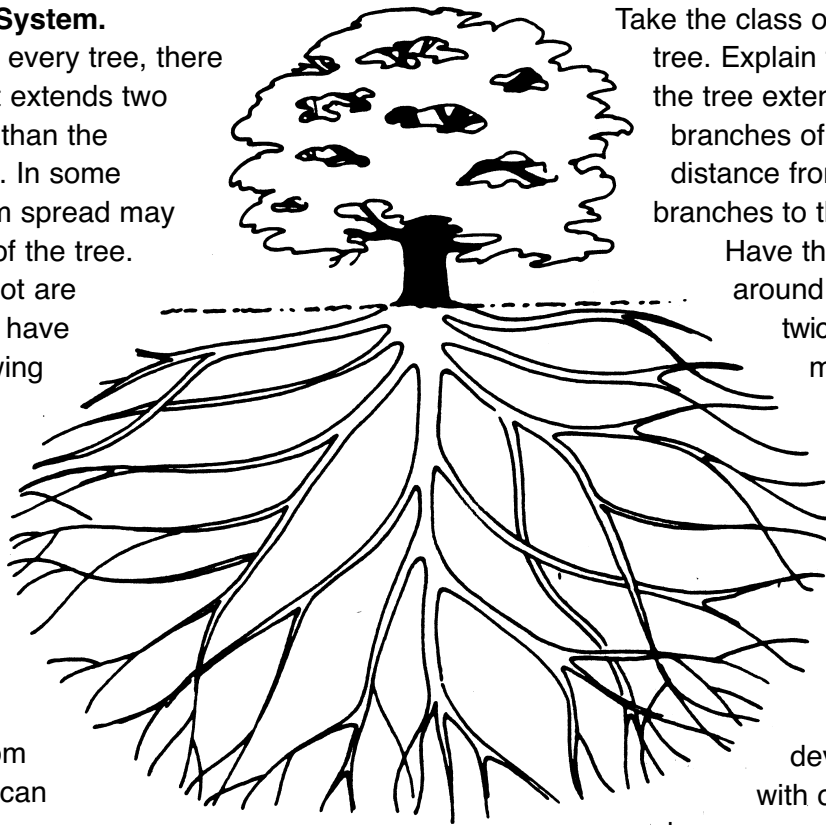

Every part of the tree is involved in this system. The roots gather water and nutrients from the soil. Water flows up the trunk to the leaves where it is combined with carbon dioxide and sunlight to make food. This food flows back down through the trunk to help all parts of the tree grow.

### PROJECTS AND ACTIVITIES

If there is a microscope or magnifying glass available, show students a prepared slide from a leaf so that they can actually see chlorophyll cells.

Take the class to a nearby tree stump, take a cross section of a log to class or purchase slices of tree branches at a craft store. Show them the layers that make a tree's food transportation system.

Explain that there is a layer of new wood for every year that the tree lived and discuss why they think this happens. Have them count the rings to see how old the tree was when it was cut. Have them try to count rings to see how big around the tree was the year they were born.

Take the class outside under a large tree. Explain that the root system of the tree extends well beyond the branches of the tree. Measure the distance from the end of the branches to the trunk of the tree.

Have the class form a circle around the tree at a distance twice as long as the branch measurement. The area encompassed contains the roots that support and feed the tree.

### EVALUATION

Divide the class into three sections. The students should develop a three-act play with one group being the leaves, one group being the trunk and one group being the root system. Each group should create its own description of the function of its part of the tree. An elected spokesperson should present the description while the others act it out.

### EXTENSION

Take a class trip to an area where maple syrup is produced. Explain that sometimes people eat the very same food that trees do—in this case maple syrup from sugar maple trees. If a sugar maple tree is available near the school, it is easy for the class to make real maple syrup.

### VOCABULARY

carbon dioxide  
chlorophyll  
phloem  
photosynthesis  
xylem

# What Do Trees Do For Dinner

# STUDENT'S GUIDE

Trees need food just like you. They make their own food. The leaves do the cooking. All they need is water, air and sunshine.

## Little Green Food Factories

When leaves are green, they are making food. They take in air. They mix in water and nutrients sent up from the roots. They use the heat from the sun to cook their dinner.

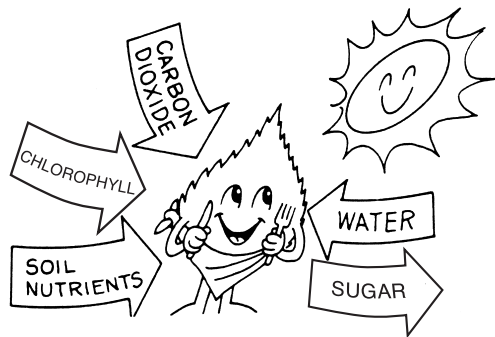

## Pipelines Inside Pipelines

Inside every tree there are hollow pipes. The roots use some of these pipes to send water to the leaves. The leaves use some of these pipes to send food to the rest of the tree. Every year a tree grows more pipes. To us they look like rings in the wood.

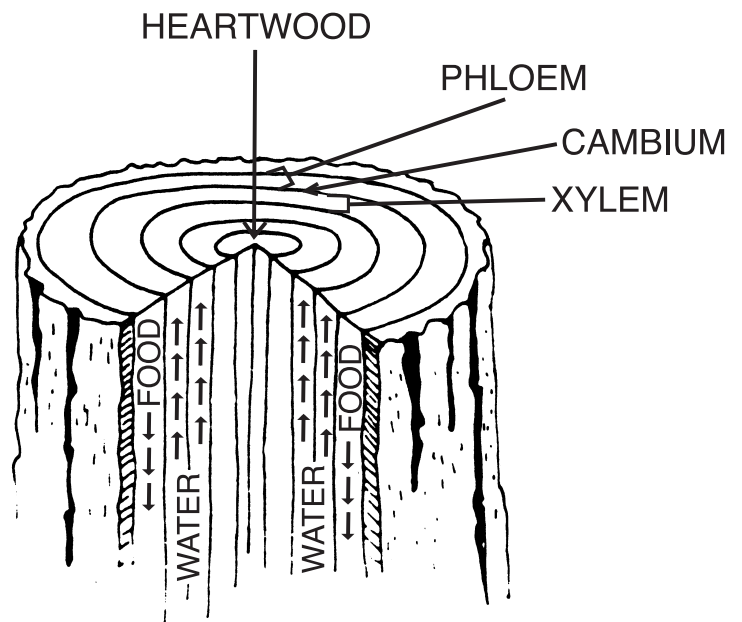

## How Trees Drink

Trees drink with their roots. They take water from the ground. Trees have more roots than they have branches. The part of the tree you can't see is bigger than the part you can! Roots have hairs like tiny straws to drink water and send it up the pipes to the leaves.

# Growing Together!

Every year that a tree grows, it forms a new ring. How many years has this tree been growing? What have you been doing while this tree was growing? Write the current year in the first blank. Fill in the years for the important events in your life. Draw a line from each year to the matching ring. Then count the rings of the tree to find out how big the tree was in each of those years. (Dates to be filled in by students.)

\_\_\_ This year's growth.

\_\_\_ I was born.

\_\_\_ I learned to walk.

\_\_\_ I learned to talk.

\_\_\_ I lost my first tooth.

\_\_\_ I started school.

\_\_\_ I met my best friend.

\_\_\_ I learned to ride a bike.

\_\_\_ I took my favorite trip to \_\_\_\_\_.

\_\_\_ Year this tree began.

**GRADE LEVEL:** PreK, 2

**NEXT GENERATION SCIENCE STANDARDS:** 2-LS4-1

**ILLINOIS EARLY LEARNING STANDARDS:** 11.A.ECa, 11.A.ECb, 11.A.ECd, 11.A.ECf, 11.A.ECg, 12.A.ECa, 12.A.ECb, 12.B.ECa, 12.B.ECb, 12.C.ECa, 13.B.ECa, 13.B.ECb

**SKILLS:** observing, gathering information, reading, communication

**OBJECTIVE:** Students will learn that in the forest, and in all of nature, there are millions of living things and that each one has a unique role to play.

# TEACHER'S GUIDE

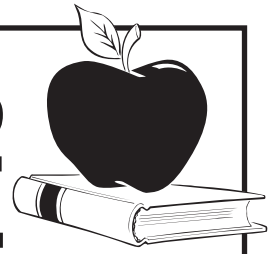

## UNIT TWO ■ LESSON THREE

# Bugs, Beavers, Birch Trees and Birds

### BACKGROUND

How many types of living things are there in the world? Believe it or not, no one knows. Scientists have identified more than a million and a half different kinds of living things: animals, plants, fungi and others. More than 54,000 species live in Illinois. But scientists also know that there are millions of other living things that have not yet been identified or named.

There is a big word to describe the fantastic variety of things in this world. The word is biodiversity. "Bio" means life, and "diversity" means lots of different forms of it. In Illinois you can begin to understand the importance of biodiversity by studying bugs, beavers, birch trees and birds.

**Working Together in the Woods.** In even a small wooded area there is an amazing variety of life. Every living thing in the woods has its own unique role to play. If there were no bugs or worms, we would not have soil to grow food and forests. If there were no good soil, there could be no trees. If there were no trees, there could be no beavers or birds. Bugs and worms are major contributors to the foundation of our forests.

**Biodiversity Basics.** Trees are important to us also because they contribute to the oxygen that we need. Large stands of trees and other plants are needed to continually provide oxygen to the atmosphere. Many organisms, from bacteria to mammals, live within forested areas. These living things are important to the health of the forest. Bugs and worms burrow in dead plants to help make soil. Trees grow in the soil. Animals live in the trees and eat seeds, nuts and fruits. They help plant more trees so there are always fresh trees when old trees die.

That is why it is important to understand every kind of living thing. Sometimes even scientists do not understand the job that a single organism does. But scientists know that every job in nature is important.

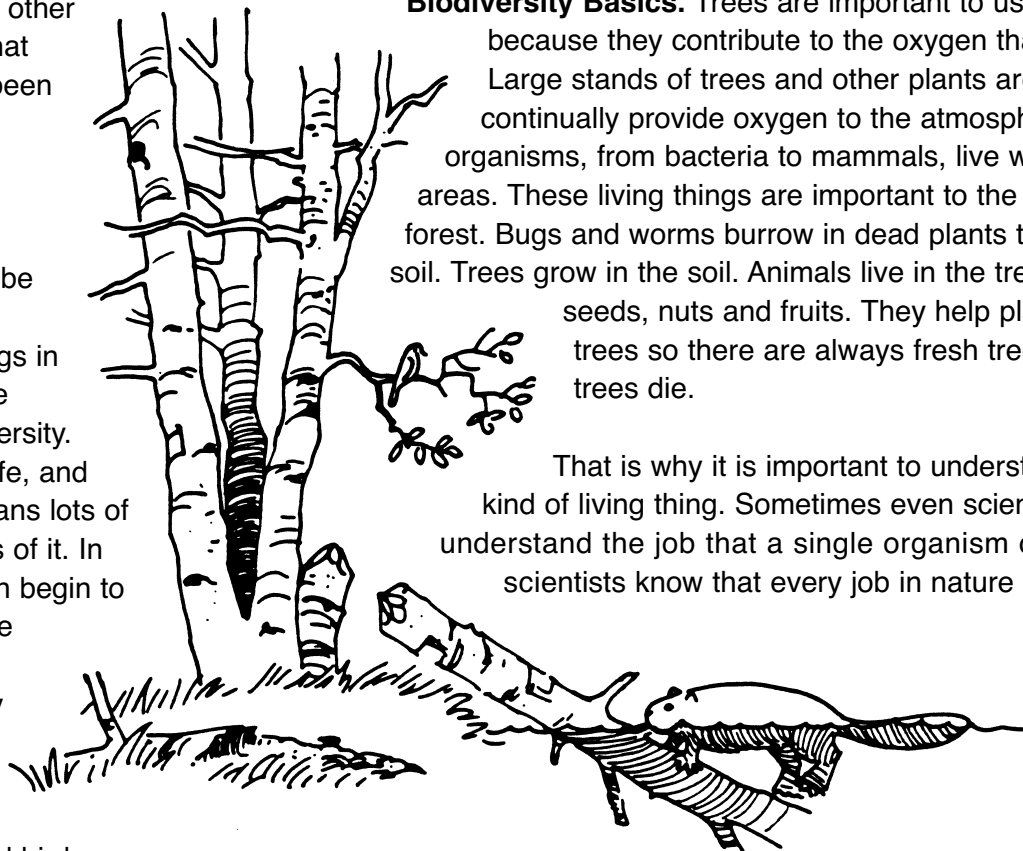

## PROJECTS AND ACTIVITIES

Take the students on a walking trip around the school grounds or the block. How many kinds of living things can they identify? Keep a list. Have them take their time, and since they are looking for diversity, be as specific as possible. Include people, different kinds of animals, plants, fungi and other organisms. If they see dogs, list different kinds. Look for differences in trees and shrubs. Don't forget grasses and insects. Even in an urban setting, the length of the list should surprise students.

Divide the class into five groups. Each group should be assigned to draw or bring to class pictures of different things that live in the woods. One group should be assigned to trees, one to smaller plants, one to mammals, one to birds and one to insects. Offer a prize to the group that can find the largest number of living things.

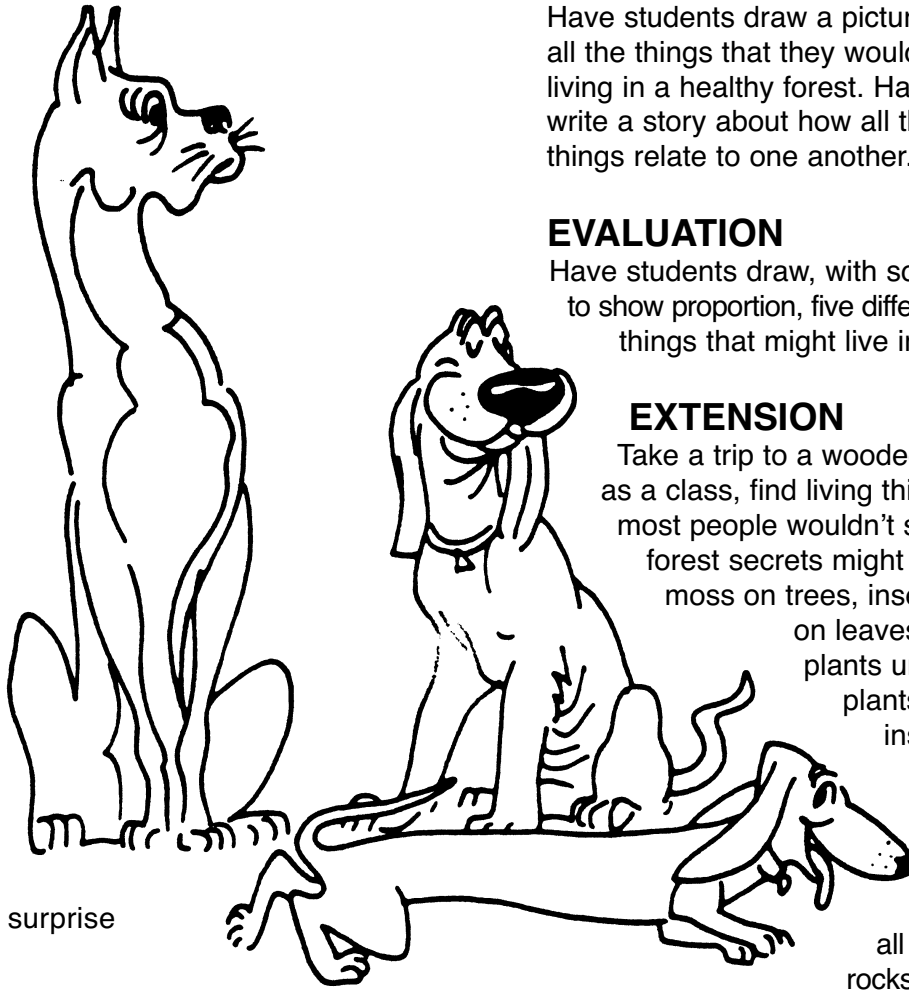

Have students draw a picture to include all the things that they would like to see living in a healthy forest. Have them write a story about how all these living things relate to one another.

## EVALUATION

Have students draw, with some attempt to show proportion, five different-sized things that might live in a forest.

## EXTENSION

Take a trip to a wooded area and, as a class, find living things that most people wouldn't see. Such forest secrets might include moss on trees, insect larvae on leaves, small plants under large plants and insects under logs or rocks. (Be sure to return all logs or rocks to their original positions. It

is wise to use a hoe to pull back logs or rocks before reaching under them.) Keep a list of the things you find and, in the classroom, discuss the role that these hidden life forms might play in the woods.



## VOCABULARY

biodiversity  
species

# Bugs, Beavers, Birch Trees and Birds

# STUDENT'S GUIDE

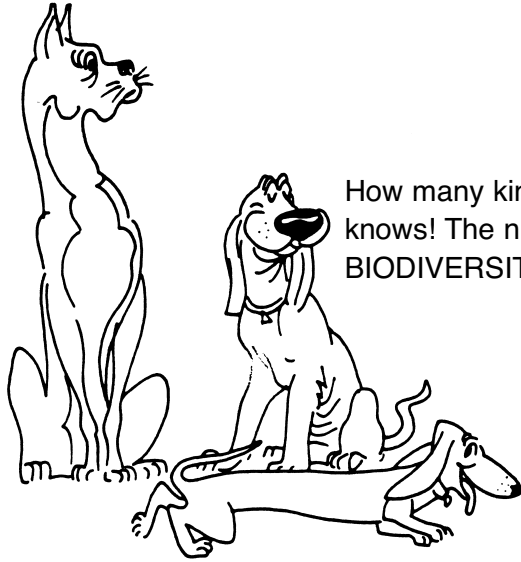

How many kinds of living things are there in the world? No one really knows! The number is so big, there is a very big word to describe it . . . BIODIVERSITY.

## Working Together in the Woods

There are lots of living things in every woods. And they all work together. Bugs and worms dig in soil to help make it better. Trees grow in the soil. Some animals live in the trees. If there were no bugs, there could be no woods.

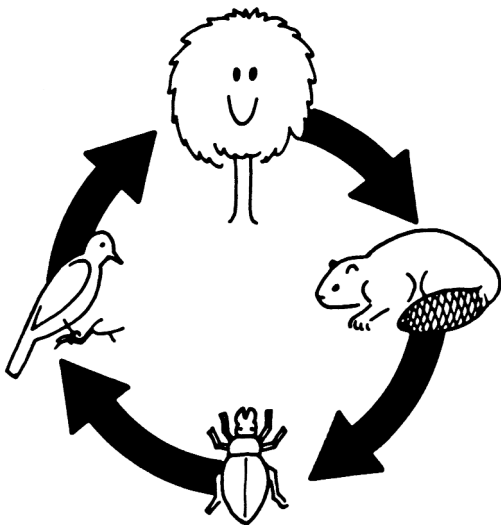

## Biodiversity Basics

In Illinois, there are very big forests and smaller forest areas, too. Forests help make the oxygen that we breathe. Millions of plants, animals and other living things live in the forests. Each of these organisms has a job to help the forest survive. If there were no bugs, there would be no forest. There would be less oxygen. Every job in nature is important.



# Forest Secrets

Lots of different animals live in every forest. In this one there are 14 different kinds of mammals, birds and insects.

Can you find them all?  
Color each animal as you find it. Then color in the woods, and they will be hard to find again!

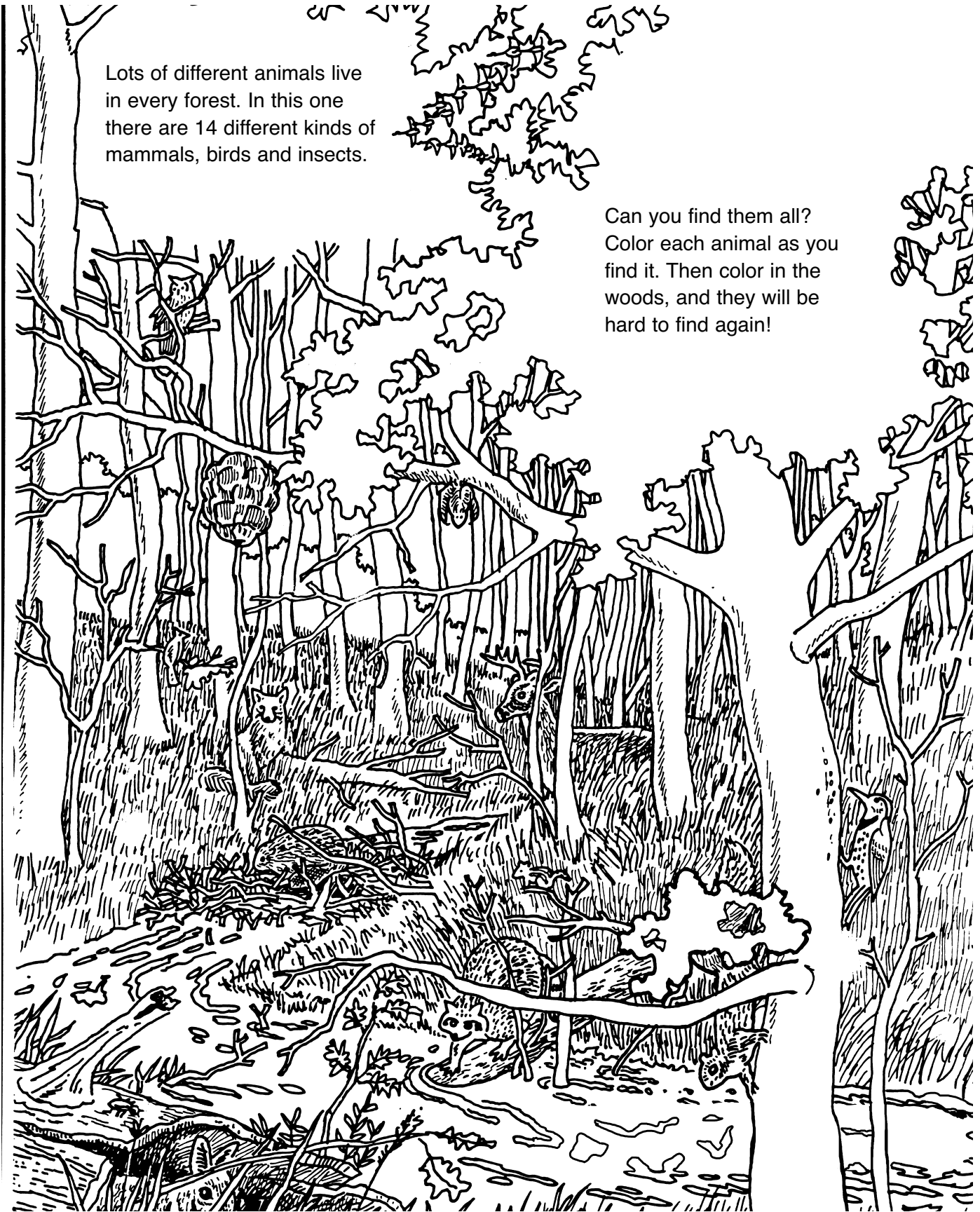



**GRADE LEVEL:** PreK

**ILLINOIS EARLY LEARNING STANDARDS:** 11.A.ECa, 11.A.ECb, 11.A.ECe, 11.A.ECf, 11.A.ECg, 12.A.ECb, 12.B.ECb, 12.E.ECb

**SKILLS:** observing, critical thinking

**OBJECTIVE:** Students will learn that although we use trees for many things in our daily lives, if we plan carefully, we will never run out of trees.

# TEACHER'S GUIDE

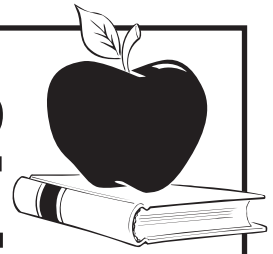

## UNIT THREE ■ LESSON ONE

# Trees for Tomorrow

### BACKGROUND

Some of the natural resources that we use cannot be replaced. We burn gasoline in our cars. Gasoline comes from oil that took millions of years to make deep within the earth. Coal is often used to make the electricity that lights our homes. Coal, too, took millions of years to make.

Trees are called a renewable resource because they can be replaced. But that does not mean we can waste trees. It takes a long time to replace a tree. Before any tree is cut, there should be a plan to replace it. For every tree that is cut, there should be a tree or trees planted to replace it.

**Christmas Tree Farm.** Trees that are used during Christmas are a good example of how trees can be replaced. No one wants to run out of Christmas trees, so they are grown on carefully managed farms . . . just like vegetables. Christmas trees are harvested when they are the right size, which takes from five to 10 years. When trees are cut, new trees are planted so that every year there is a fresh crop of Christmas trees ready.

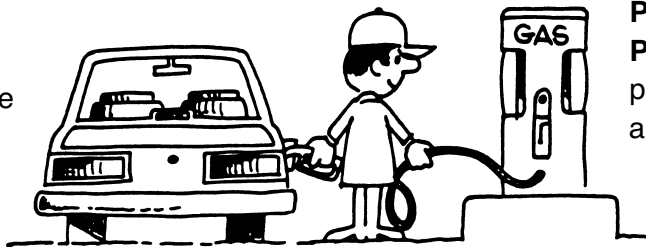

### Paper-Makers Are Big Tree Planters.

The trees used to make paper are usually pines, spruces and firs (softwoods), just like Christmas trees, only much bigger. Millions of acres are devoted to growing trees to make paper. When trees are cut, lots of

trees are planted. This must be very carefully planned because it takes from 15 to 80 years to grow a tree big enough to make paper.

**Planning for Future Forests.** Hardwood trees are used to make furniture, floors, bowling alleys and baseball bats. The things that we make from these trees—which include oak and hickory trees—can last a very long time. So with careful planning we can replace hardwood trees as we use them.



## Trees For Your Tomorrow.

Remember, we don't just plant new trees so we can make things from them. Someday your students will have children. And those children will enjoy sitting under a cool oak tree on a hot summer day. They'll swim in lakes and streams that are clear because tree roots hold the soil in place. And they'll enjoy the wonderful, colorful spectacle of a trip through the country on a sunny autumn day.

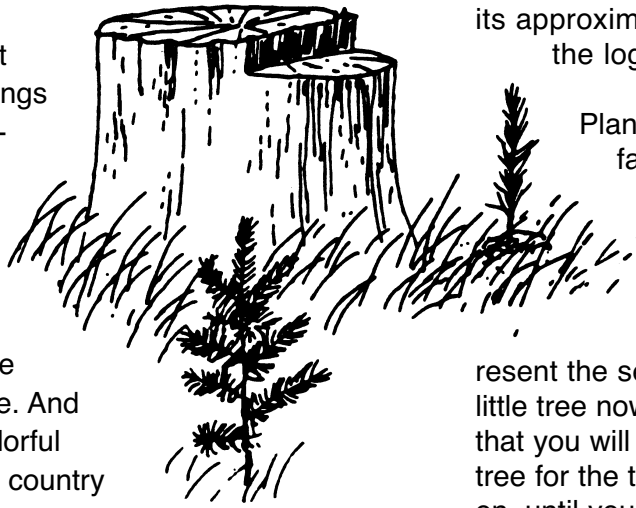

its approximate age in comparison to the log.

Plan a simple Christmas tree farm on the chalkboard.

Draw a small Christmas tree that has just been planted and explain that in one year it will grow.

Draw a larger tree to represent the second year of growth. The little tree now represents a new tree that you will plant. Add a third larger tree for the third year of growth. And so on, until you have five trees on the board. The biggest one is ready for Christmas. Now ask the class to discuss how the farm can be managed in the future so that every year there will be one perfect Christmas tree. Ask the students to draw a picture of their own Christmas tree farm.

## PROJECTS AND ACTIVITIES

Have students, with their parents' help, identify the oldest product in their home that is made from wood. Students should draw a picture of the product and bring it to class for a show and tell session where students describe the product, its age and any interesting stories associated with it.



Have the class begin a recycling project and collect classroom paper for recycling. Measure the amount of paper collected and keep records of how much the class recycled during the year.

Bring a cross section of a small log to class and count the rings to determine its age. Measure the circumference of the log with string and record it. Take the class on a short tree hike, around the perimeter of the school or in a neighborhood and have the students guess the ages of the trees they see by comparing them to the circumference of the log. Measure the circumference of the largest tree you find. Back in class try to determine

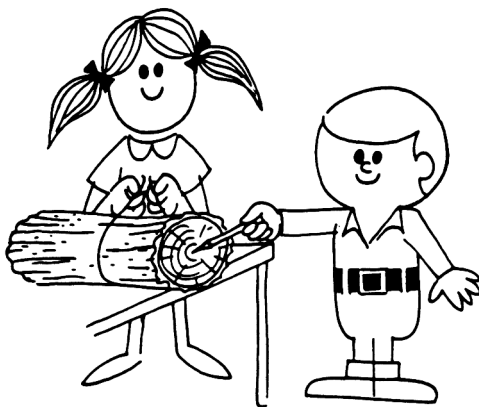

## EVALUATION

Some products made from trees we use up quickly, paper for instance. Other products last a long time. Some trees grow faster than others. Have the class discuss, based on this information, what type of products we might want to recycle and why.

## EXTENSION

Take the class on a field trip to a Christmas tree farm where trees have recently been planted. Have the owner or manager explain the plan they use to plant and harvest trees. If there is no Christmas tree farm nearby, visit a nursery where the growth rate of trees can be demonstrated.

## VOCABULARY

compost  
mulch  
natural resource  
renewable resource

# Trees for Tomorrow

# STUDENT'S GUIDE

When we use trees to make things, we can grow new trees.

## Merry Christmas

We won't run out of Christmas trees. Tree farmers plant new ones.



## Paper-Makers

It takes lots of trees to make paper. Paper-makers plant millions of new trees every year.

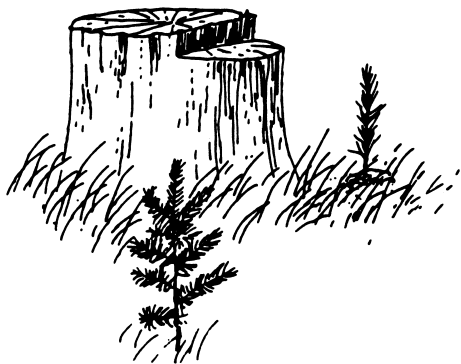

## Hard Wood

Some trees have very hard wood. The things we make from them usually last a long time.

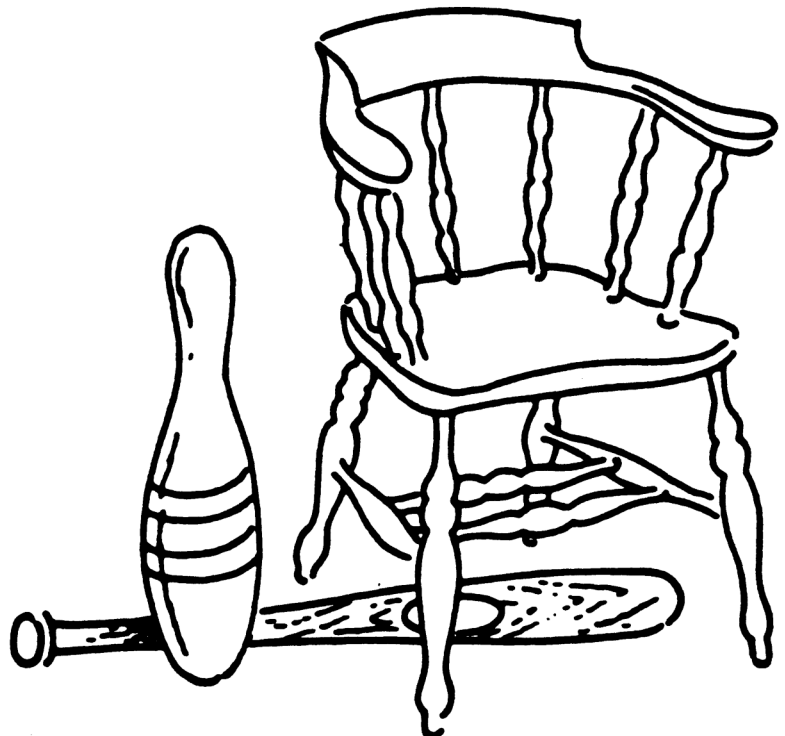

# Make a Lunch Bag Tree Puppet!

## What you will need

- a lunch-size paper bag
- green, brown and white construction paper
- paste
- scissors
- crayons or markers

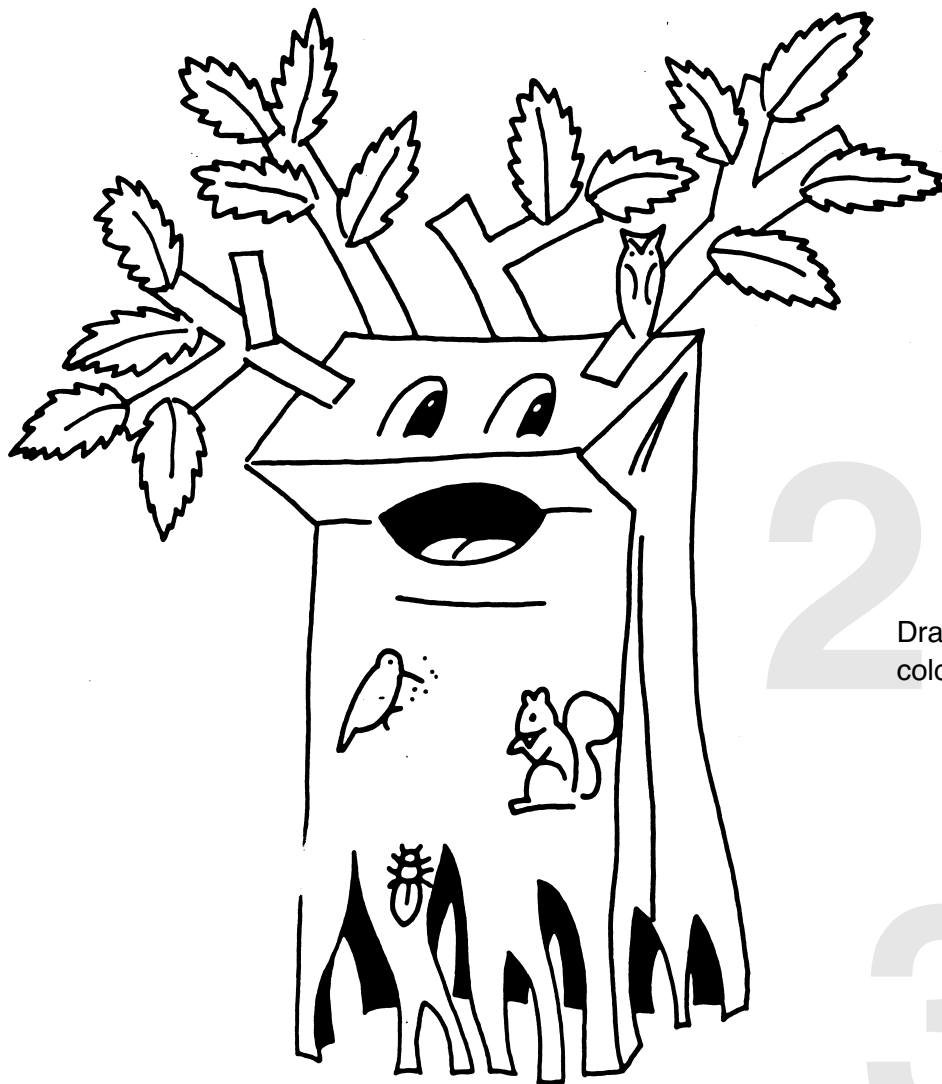

1  
Make your own talking tree. Start with a lunch-size paper bag. Cut away strips at the bottom to make roots.

2  
Draw eyes and a mouth as shown and color the bark on your tree.

3  
Paste on branches made from construction paper.

4  
Make leaves from construction paper and paste them on. You can also use real leaves.

5  
Decorate your tree with animals. You can draw them on, cut them from construction paper and paste them on or use stickers.

**GRADE LEVEL:** PreK

**ILLINOIS EARLY LEARNING STANDARDS:** 12.E.ECb,  
15.A.ECa

**SKILLS:** gaining information, reading, communication

**OBJECTIVE:** Students will learn that there are many types  
of jobs that people do in the forest.

# TEACHER'S GUIDE

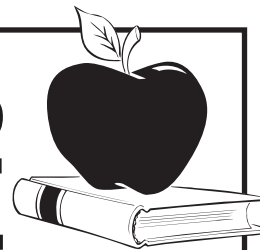

## UNIT THREE ■ LESSON TWO

# People Who Work in the Woods

### BACKGROUND

Many lucky people get to work in the woods. They do a variety of jobs that are important for a lot of different reasons. Most of these jobs require a college education.

**The Forests' Best Friends.** Forests are large areas of land covered with trees and other plants. Forestry is the part of science that studies how to protect forests and make them productive. Foresters are the scientists who manage forests to keep them healthy and help people understand and use the forest wisely. The main job of foresters is to manage the forest and help trees grow. They measure trees. They fight forest fires and plan how to prevent fires. They decide when it is time to harvest, or cut down, trees. When there is a problem in the forest—when the trees are sick with a disease, when the animals living there do not have enough to eat, when the water has become polluted—foresters find ways to solve the problem.

Forest rangers are the forests' friends, too. Their job is to help people understand

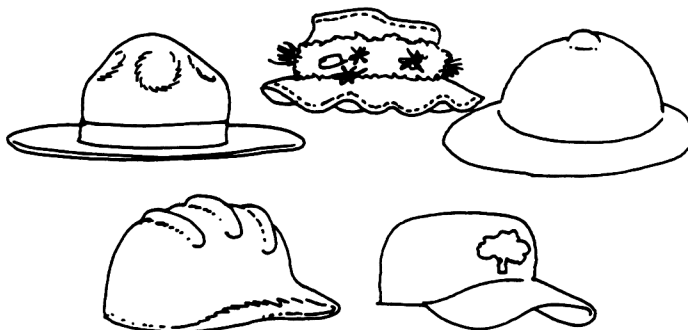

and enjoy the forest. They teach people how to enjoy the forest without hurting it by causing fires, throwing away litter or destroying plants.

**The Woods Are Full of "ists."** Not all scientists wear

white coats and work with test tubes in laboratories. Many kinds of scientists work in the forest. For them the forest is like a big laboratory. All of these kinds of scientists study special things, and their names all seem to have an "ist" on the end. Botanists study plants. Zoologists study animals. Ornithologists study birds. Herpetologists study snakes and frogs. Entomologists study insects. Ichthyologists study fishes. That's just a few of the "ists" in the woods. Fish and wildlife biologists study and manage the wildlife, especially game species.

**At a Nursery.** In a hospital a nursery is where a newborn baby stays until he/she goes home. Did you know there are tree nurseries too? People who work in nurseries grow new trees, shrubs and other plants. Trees start from seeds grown in seed beds, sometimes in a special glass building called a greenhouse. Some trees and shrubs are grown from cuttings. Cuttings are small pieces of a branch from a tree or shrub that are used to grow new trees and shrubs. When trees become a little bigger (seedlings), workers transplant them in fields where they have more room to grow. When the seedlings become a little bigger (saplings) they are ready to be transplanted again to their permanent homes—to yards, streets, parks, orchards and even to the forest.

**Timber.** Many people have jobs in the timber industry. They harvest trees to make wood products and paper. That's right! The paper on your desk came from a tree! People then plant new trees to take the place of the ones that they cut down. It is important that the people in the timber industry are careful because it takes good management to grow trees as a renewable resource.

## PROJECTS AND ACTIVITIES

Invite a forestry-related professional to visit the class and make a presentation on the nature of his or her job.

After discussing different types of jobs in the forest, ask students to think about what their favorite forest job would be.

Students should draw a picture pertaining to his or her ideal forest job and be prepared to present it to the class and explain the job. Discuss some of the specialized scientists who work in the woods—biologists, zoologists, herpetologists and others. Have the class create names for some new, highly specialized “ologists.” What might they call a scientist who studies hollow trees? Or a scientist who studies tadpoles? Or a scientist who studies owls? Encourage students to make up their own “ologists.”

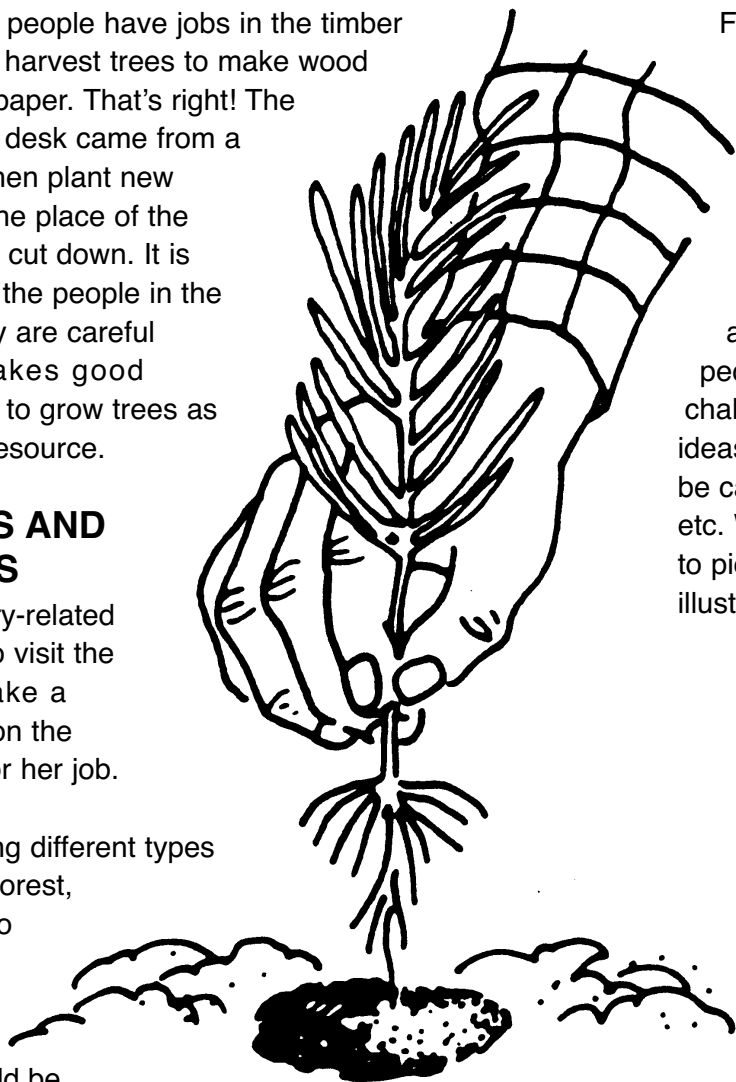
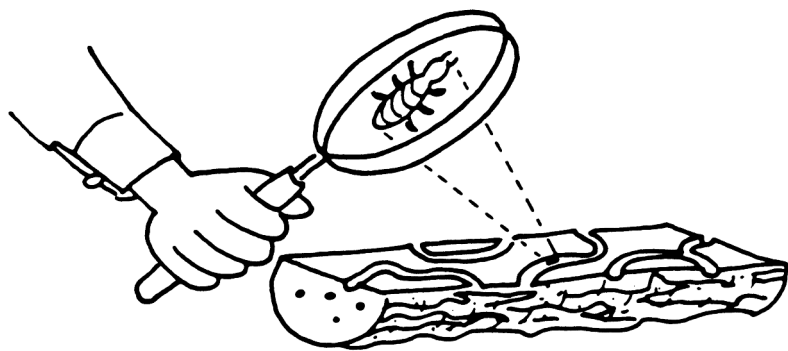

Forest rangers teach people how to protect the forest. Foresters and Conservation Police Officers also protect the forest by making sure timber is not illegally cut and that special plant and animal populations are not removed or harmed. Start a class discussion on ways that people can protect the forest. On the chalkboard keep a list of the students' ideas which might include: don't litter; be careful with fire; don't harm plants, etc. When you have a list, ask students to pick one idea and draw a picture that illustrates it.



## EVALUATION

Have each student visit the school library or public library to find and read a book about people who work in the woods or a book that features someone who works with trees. Have each student share his/her book with the class.

## VOCABULARY:

botanist	ornithologist
cutting	productive
entomologist	renewable
forester	resource
forestry	sapling
game	seedling
greenhouse	timber industry
harvest	transplant
herpetologist	wildlife biologist
ichthyologist	zoologist
management	

# People Who Work in the Woods

# STUDENT'S GUIDE

Many people have jobs in the woods.

## The Forest's Best Friends

Foresters study the forest and protect it.

## In the Forest, Lots of Scientists Study Lots of Things.

They study plants. They study bugs. They even study fish.

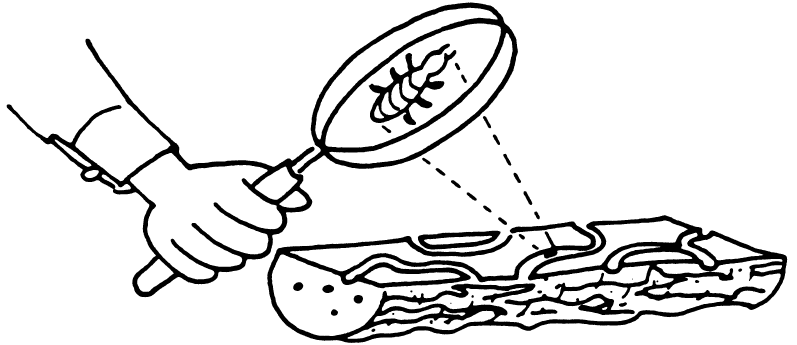

---

## At the Nursery

People who work in nurseries grow new trees. They may start with a tiny seed. When the tree is big enough, they move it to a new home.

## Timber!

Cutting down trees is a big job. Trees must be cut to make paper, houses and furniture. Planting new trees is a big job, too. Planting trees helps us to make sure that many trees will be mature in years to come.



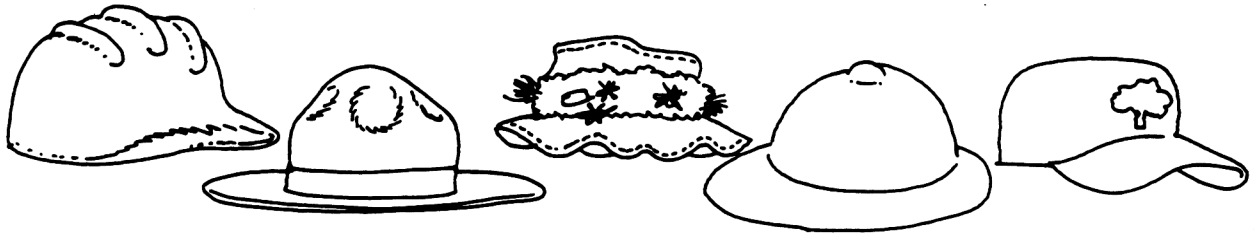

# Whose Hat is This?

Color these five people who work in the woods. Can you guess what their jobs are? Color their hats and cut them out. See if you can put the hats on the right people.





**GRADE LEVEL:** PreK, K, 2

**NEXT GENERATION SCIENCE STANDARDS:** K-ESS3-1, K-ESS3-3, K-LS1-1, 2-LS4-1

**ILLINOIS EARLY LEARNING STANDARDS:** 11.A.ECb, 11.A.ECd, 11.A.ECf, 11.A.ECg, 12.A.ECb, 12.B.ECa, 12.B.ECb, 12.E.ECb

**SKILLS:** observing, critical thinking, communications

**OBJECTIVE:** Students will learn how to plant a tree and how to select a site that will not interfere with power lines or stunt the growth of the tree.

# TEACHER'S GUIDE

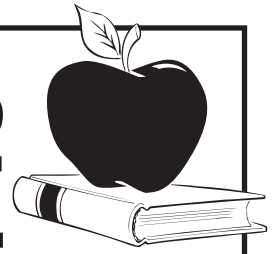

## UNIT THREE ■ LESSON THREE

# Let's Plant a Tree

### BACKGROUND

Planting trees is a very rewarding thing to do. Trees add beauty to our world, provide homes and food for animals, grow to provide wood for homes and paper for books and help the environment. Planting trees is also easy and fun. There are just a few rules to follow.

**What to Plant.** The trees we plant in our yards, parks and along streets are called saplings. Their size is somewhere between small seedlings and mature trees. If students were trees, they would be saplings. Saplings are usually ready to plant when we buy them. Their roots are well developed and contained neatly in a pot or in a ball of soil wrapped in burlap. If there are any ropes around the tree and roots, they must be cut.

**How to Plant.** Dig a hole about twice as wide as the root ball on the tree. If the tree is in a pot, remove it from the pot and place it in the hole. If it has a ball of soil wrapped in burlap, place it in the hole and cut any twine which is wrapped around the trunk. The top of the ball should be slightly higher than the

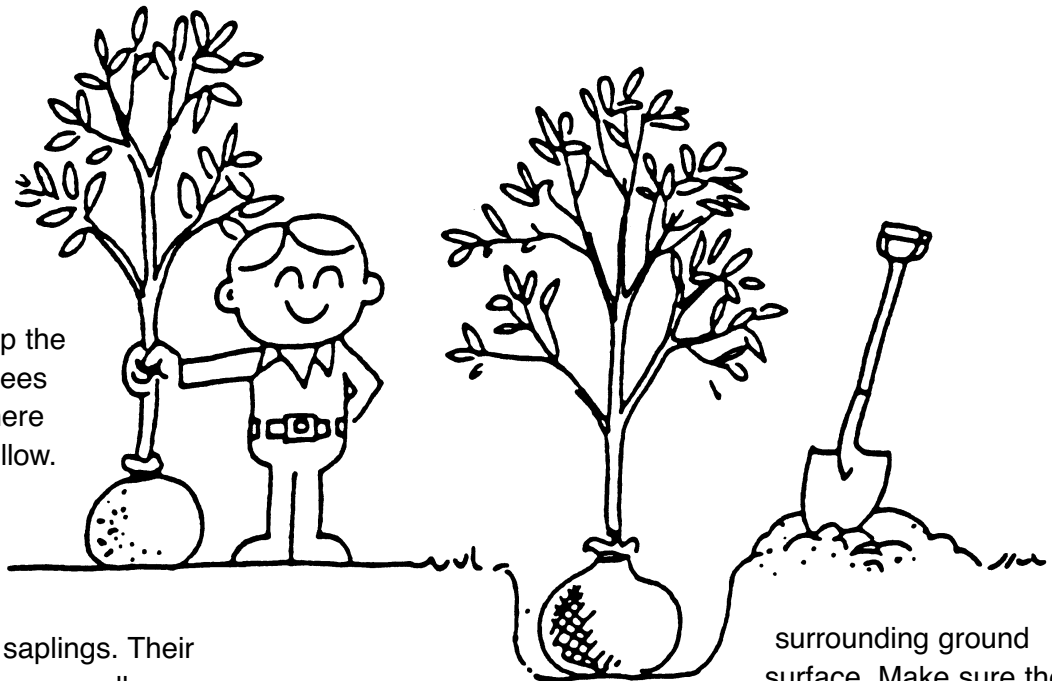

surrounding ground surface. Make sure the tree remains straight and fill in the hole with the dirt you removed, pressing it down gently with your foot. Place a bark mulch around the base of the tree to cover the entire area of the hole. This will help hold in moisture. Mulch should be four inches deep, four feet wide and spread evenly. Pull mulch back two inches from the trunk. Water the tree thoroughly and then water it any time the soil begins to dry out. That's all there is to planting a tree.

**Where to Plant.** Planting is easy, but you must be very careful selecting the location for the tree. The location will be determined by the mature size of the tree. Look up. Are there any electric wires overhead? If so, would the tree grow into the wires? Look down and around. Are there electric wires underground? It is very dangerous to dig a hole if there are buried electric lines. These are difficult to locate, but people at the electric and telephone companies know where the lines are buried

and you can call JULIE (Joint Utilities Locating Information for Excavating) at 1-800-892-0123 to find out if any lines are buried where you want to dig. Look all around. Your tree needs room to grow. Is it too close to a house? Is it too close to another tree? Your tree will get water through its roots underground so there should not be a lot of concrete or asphalt surrounding your tree. Put three stakes around your tree to protect it from mowers and other lawn care equipment.



have been avoided by planting the tree elsewhere? Invite a representative from your local power company to explain their company's forestry program. Why must trees be pruned? Are there different ways to prune trees? Are there kinds of trees that can be planted

under power lines? Invite a local tree nursery professional to your classroom to discuss tree planting and tree care.

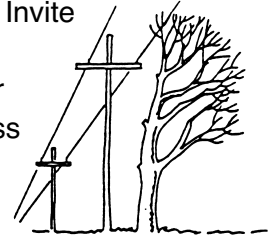

**Future Care.** Trees need special attention so you should find out as much about your kind of tree as you can. Ask for care instructions at the nursery or garden center where you bought your tree. You can have the fun of taking care of and watching your tree grow for years.

## PROJECTS AND ACTIVITIES

**Plant a Tree!** Select a location on the school grounds or elsewhere. Discuss with the class what kind of tree would be appropriate. Plant a tree that is native to Illinois. Find out as much as you can about that kind of tree. Examine the location carefully. Make sure there are no power lines. Call JULIE to check for underground cables. Make sure there is plenty of room for the tree to grow. Plant your tree in the spring, perhaps on Arbor Day (the last Friday in April).

Take the class on a neighborhood walk to find trees that have been incorrectly planted. What happens to a tree when it is too close to a building? Find trees that have been pruned because they were interfering with wires. Could this problem

## EVALUATION

On a large piece of paper draw an aerial view of a street, including the street, several houses, sidewalks, driveways and power lines (above and below ground). Place the paper on the floor so students may walk around and across the neighborhood. Using green (conifers), orange, red and yellow (fall hardwoods) construction paper make several sizes of cones to represent different sizes of trees. Have the students "plant" the trees in the best location.

## EXTENSION

Take the class on a field trip to an arboretum, city walkway, local tree nursery or a well-managed park. Arrange for a guide to conduct a tour and explain tree planting and tree care practices.

## VOCABULARY

arbor  
compost  
environment  
mulch  
pruning  
sapling



# Let's Plant a Tree

# STUDENT'S GUIDE

## Planting Trees Is Easy and Fun.

The young trees we plant are called saplings. If you were a tree, you would be a sapling.

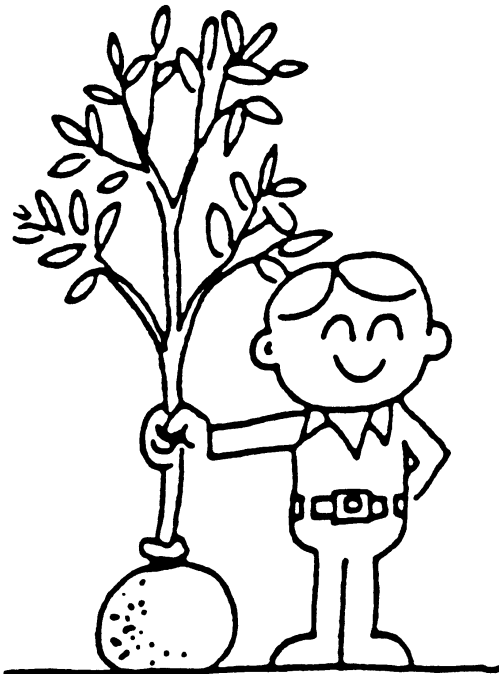

## Be Careful Where You Plant!

Trees need lots of room to grow. Look up. Look down. Look all around. Will your tree have enough room?



Illinois' Arbor Day celebration is the last Friday in April. If you plant a tree now or on Arbor Day, you can watch it grow for years and years.

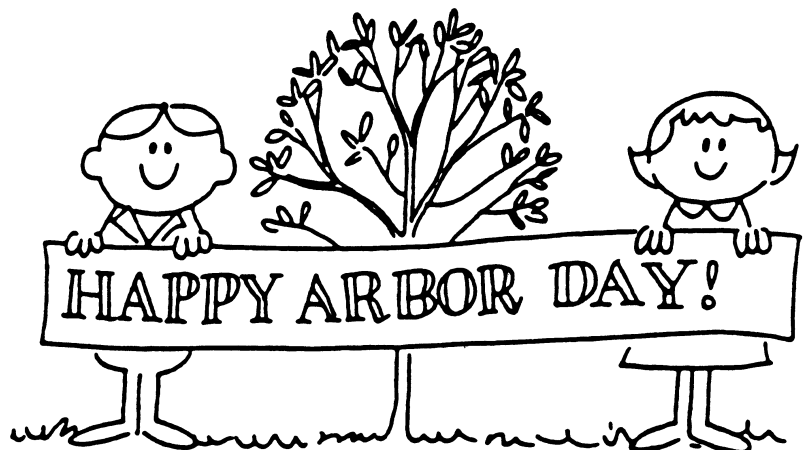

# Find the Healthy Trees

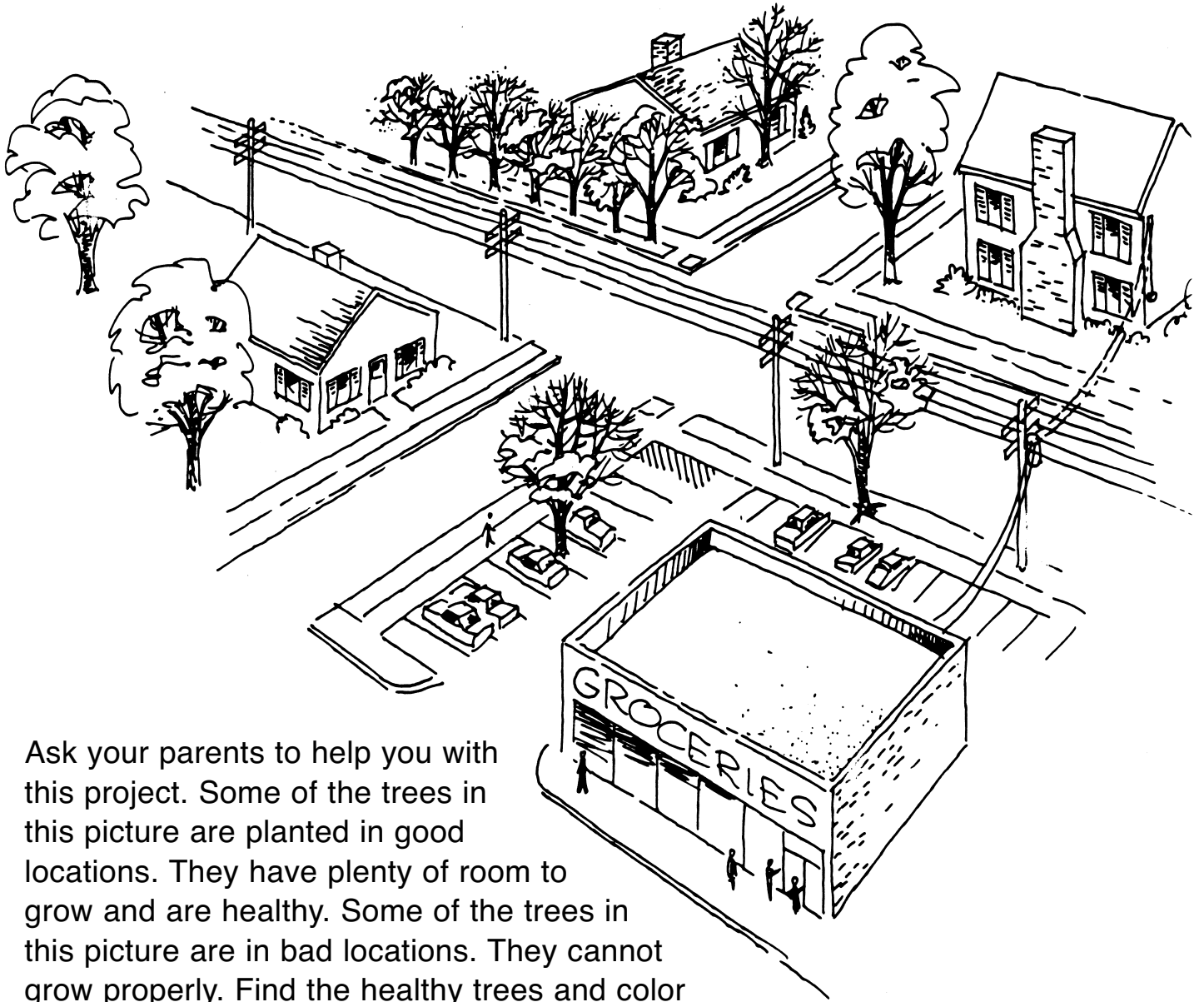

Ask your parents to help you with this project. Some of the trees in this picture are planted in good locations. They have plenty of room to grow and are healthy. Some of the trees in this picture are in bad locations. They cannot grow properly. Find the healthy trees and color them. Find the trees that are not healthy and circle them. What is wrong with these unhealthy trees? Discuss why some locations are better than others for planting trees.

# GLOSSARY

**Arbor Day** - a special day (the last Friday in April) set aside for planting new trees – Our second grade class planted three new trees on Arbor Day.

**biodiversity** - the variety of all living things on the planet – Any major loss of habitat is a threat to the biodiversity of the earth.

**bore** - to make a hole in something – The carpenter is going to bore a hole in the wood with his drill.

**botanist** - a person who studies plants – The botanist identified a new type of plant in the forest.

**cambium** - a layer of cells in the stems and roots of plants from which new phloem and xylem cells grow – The cambium is the area in a tree where annual growth occurs.

**carbon dioxide** - a gas absorbed from the air by a plant which it uses to make its own food – Trees can help clean the air by using some carbon dioxide.

**cell** - the smallest part of any living thing – Trees are made up of millions of cells.

**chemical** - a substance that is made by or has something to do with chemistry – The chemical that plants use to make food is called chlorophyll.

**chemical reaction** - the result of chemicals being combined to form a new substance – A chemical reaction happens when plants use chlorophyll to change the air and water they take in into sugar.

**chlorophyll** - substance in plants that makes them green and helps in food production – Trees use chlorophyll to make their food.

**compost** - to make a mixture of decaying organic materials to use as fertilizer – We compost our table scraps in a special area in our back yard.

**cutting** - a root, stem or leaf section removed from a plant that can grow into a new plant – My teacher gave me a cutting of the big plant in our classroom so I could grow a new plant at home.

**decay** - to break down dead organisms or their parts back to nutrients – When fallen leaves decay, they become part of the soil.

**entomologist** - person who studies insects – The entomologist said that the warm, rainy weather will bring many mosquitoes this summer.

**environment** - the surrounding area in which an organism lives – Our zoo tries to make each animal's cage like its natural environment.

**erosion** - slow wearing or washing away – Trees can help keep heavy winds and rains from causing soil erosion.

**forester** - a person trained in the science of developing and caring for forests – The forester helps to make sure the trees in the parks are healthy.

**forestry** - the science of developing and caring for forests – When I grow up, I want to study forestry.

**fruit** - the part of a plant that contains the seeds – Apples and nuts are fruits that you can eat.

**game** - wild animals that are hunted or caught (fishing) for sport and food – My Dad's favorite game bird to hunt is the wild turkey.

**greenhouse** - a building used for growing plants – The greenhouse has many windows so the plants can get lots of sunlight.

**harvest** - to gather plants or animals for human use – Sometimes we harvest trees to make furniture and other wood products.

**herpetologist** - a person who studies reptiles and amphibians – The herpetologist told me the difference between frogs and toads.

**ichthyologist** - person who studies fishes – The ichthyologist found out that the garbage being dumped in the pond was killing the fishes.

**invertebrate** - an animal with no backbone (spine) – Worms, crayfish and insects are all types of invertebrates.

**lobe** - a projection that extends out on a leaf – You can identify leaves by looking at how many lobes they have.

**management** - the control, use and replacement of renewable resources – If we use good forest management, we will always have trees.

# GLOSSARY

**mulch** - a protective covering of material spread on the ground to enrich the soil, hold in water or keep the soil at a steady temperature – The gardener spread mulch around the sapling.

**natural resources** - materials that are found in nature that are useful or necessary for people to live – Our natural resources include water, trees and minerals.

**nursery** - a place where plants are planted, raised and sold – We get trees and shrubs to plant in our yard from the nursery.

**nut** - the dry fruit of a plant with a hard outer shell and softer inside – Squirrels gather and store nuts for food to eat during the winter.

**nutrient** - something needed by animals and plants for growth – Trees make their food with help from nutrients they get from the soil.

**ornithologist** - person who studies birds – The ornithologist showed the children the marks made by the woodpecker.

**oxygen** - a gas in the air which many organisms need to survive – When a tree makes its food, it gives off oxygen.

**phloem** - cells that carry sugar from the leaves to all parts of a tree – A tree's food is moved around the tree in the phloem.

**photosynthesis** - the process by which a plant makes simple sugar using light, chlorophyll, carbon dioxide and water – All green plants use photosynthesis to make their own food.

**pigment** - a substance that is used in coloring or dyeing – The green pigment in leaves will fade when there is no sunshine or water.

**productive** - making large amounts of something that is good and useful – A forest is productive because it provides shelter and food for the organisms that live in it.

**pruning** - to cut away unwanted parts of a tree to help it grow better – Pruning the dead branches can help trees grow fuller and taller.

**renewable resources** - living parts of the environment that can renew or replace themselves – Renewable resources like trees and grasses can grow back even if they are cut.

**sap** - liquid that flows through a tree – The sweet sap of a sugar maple tree is used to make maple syrup.

**sapling** - a young tree usually less than four inches in diameter when measured at chest height – A sapling needs special care when it is transplanted.

**species** - groups of organisms that have certain things about them that are alike – White oak and black oak are two different species of trees.

**seed** - the part of a plant from which a new plant can grow – We planted the seeds just last week, and we can already see sprouts.

**seedling** - a young tree usually no taller than two feet that is grown from a seed – Our old maple tree has many young seedlings growing around it.

**succession** - natural process of change on an area from one form of vegetation to another – The old farm field over time became a forest through the process of succession.

**timber industry** - businesses that manufacture and use tree products – The people who work in the timber industry choose carefully which trees should be cut down for making paper and other wood products.

**transplant** - to move a plant from one growing place to another – Each spring we transplant flowers from flowerpots to our front yard.

**vein** - a system of tubes that carries food and water in a leaf – You can recognize the leaves from different types of trees by the shapes of their veins.

**wildlife biologist** - someone who studies and manages animal populations and habitat – The wildlife biologist told us that there are wood ducks nesting by our farm pond.

**xylem** - cells in a tree that carry water and minerals from the roots to the trunk, branches and leaves – A tree's water and minerals are moved around the tree in the xylem.

**zoologist** - someone who studies all forms of animal life – The zoologist told us that all animals need shelter to survive.

# SUGGESTED FIELD TRIP SITES

Visit one or more of these Illinois Department of Natural Resources sites to continue your study of trees and other natural resources. Call in advance of your visit to make arrangements with site personnel. If none of these sites are close enough to visit, plan a trip to a local park, nature center or nature preserve.

<b>REGION I</b>	<b>COUNTY</b>	<b>EMPHASIS</b>
1) Mississippi Palisades 815-273-2731	Carroll	geology, wildlife
2) Lake Le-Aqua-Na 815-369-4282	Stephenson	wildlife
3) Rock Cut 815-885-3612/3311	Winnebago	geology, wildlife
4) Johnson-Sauk Trail 309-853-5589	Henry	wildlife
5) Hennepin Canal Parkway 815-454-2328	Henry/Bureau	visitors' center, history
6) Argyle Lake 309-776-3422	McDonough	visitors' center, wildlife, forest, geology
7) Rice Lake 309-647-9184	Fulton	waterfowl, river
8) White Pines Forest 815-946-3717	Ogle	forest, stream
9) Shabbona Lake 815-824-2106	DeKalb	lake
10) Big River State Forest 309-374-2496	Henderson	forest
11) Starved Rock 815-667-4726	La Salle	visitors' center, forest, river, geology
<b>REGION II</b>		
12) Silver Springs 630-553-6297	Kendall	wildlife
13) Moraine Hills 815-385-1624	Lake	geology
14) Volo Bog 815-344-1294	McHenry	visitors' center, geology
15) Illinois Beach 847-662-4811	Lake	visitors' center, natural area, lake
16) Goose Lake Prairie 815-942-2899	Grundy	visitors' center, prairie, wildlife

# SUGGESTED FIELD TRIP SITES

17) Kankakee River  
815-933-1383

Kankakee

visitors' center, river

## REGION III

18) Fox Ridge  
217-345-6416

Coles

wildlife, streams

19) Kickapoo/Middle Fork  
217-442-4915

Vermilion

river, wildlife

20) Spitler Woods  
217-864-3121

Macon

forest, wildlife

21) Weldon Springs  
217-935-2644

De Witt

visitors' center, geology

22) Moraine View  
309-724-8032

McLean

wildlife

23) Hidden Springs State Forest  
217-644-3091

Shelby

forest

## REGION IV

24) Beaver Dam  
217-854-8020

Macoupin

wildlife

25) Pere Marquette  
618-786-3323

Jersey

visitors' center, forest,  
natural area, geology, river

26) Western Illinois Complex  
217-894-6205

Adams/Brown

geology

27) Baldwin Lake  
618-785-2555

Randolph

geology, river,  
wildlife

28) Sangchris Lake  
217-498-9208

Sangamon/Christian

mammals, waterfowl



# SUGGESTED FIELD TRIP SITES

29) Eldon Hazlet  
618-594-3015  
Clinton  
visitors' center, lake, wildlife

30) Jim Edgar Panther Creek  
217-452-7741  
Cass  
forest, wildlife

## REGION V

31) Beall Woods  
618-298-2442  
Wabash  
visitors' center, forest, river

32) Fort Massac  
618-524-4712  
Massac  
history, river

33) Newton Lake  
618-783-3478  
Jasper  
fishery, wildlife

34) Stephen A. Forbes  
618-547-3381  
Marion  
wildlife, forest

35) Giant City  
618-457-4836  
Jackson  
visitors' center, forest, wildlife,  
geology

36) Ferne Clyffe  
618-995-2411  
Johnson  
natural area, geology, wildlife

37) Cache River  
618-634-9678  
Johnson/Union  
visitors' center,  
natural area, wildlife

38) Trail of Tears  
618-833-4910  
Union  
forest, natural area

39) Lake Murphysboro  
618-684-2867  
Jackson  
forest, wildlife,  
geology

40) Wayne Fitzgerald  
618-629-2320  
Franklin/Jefferson  
wildlife, waterfowl

# Location of Suggested Field Trip Sites

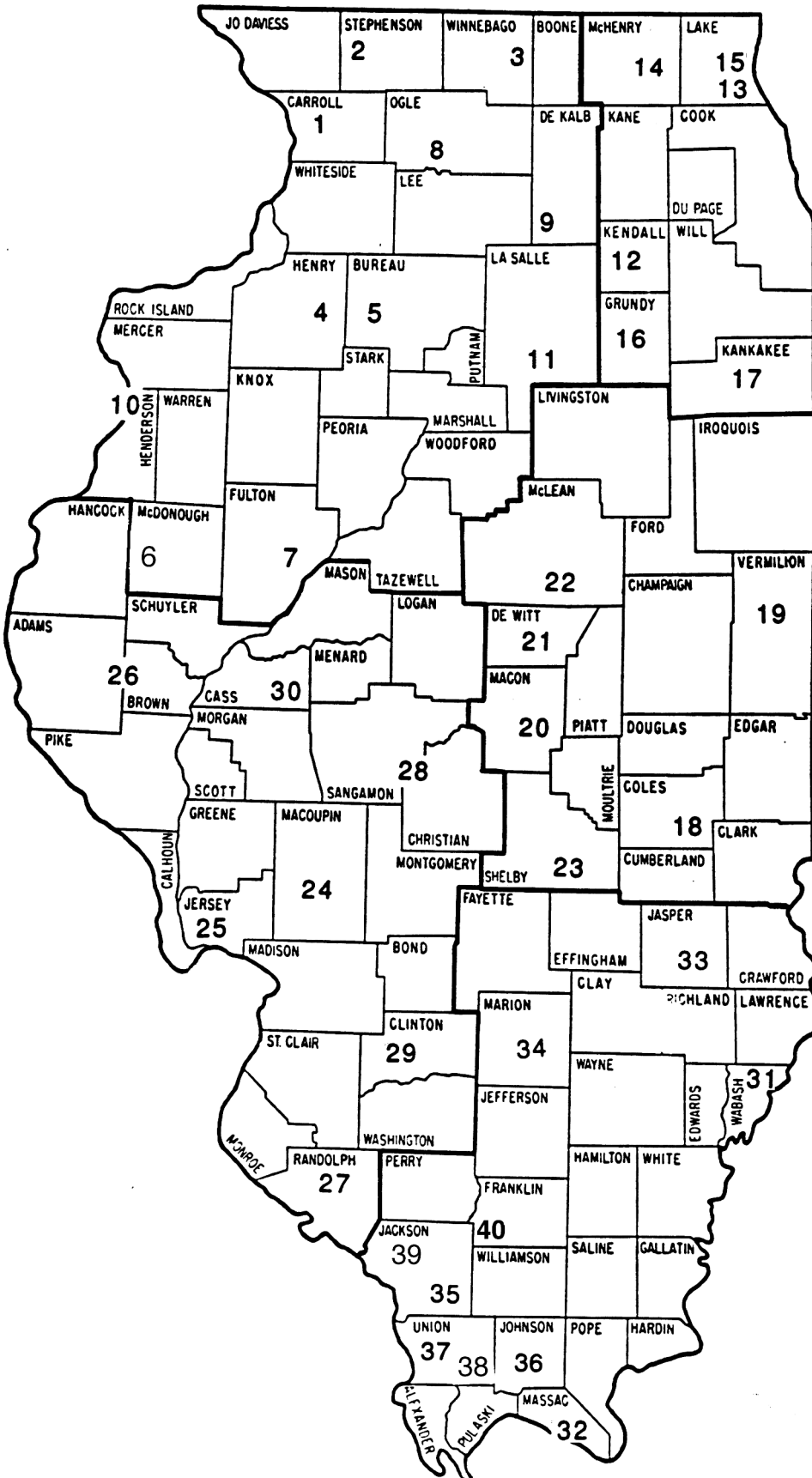

# Maple Mix-up

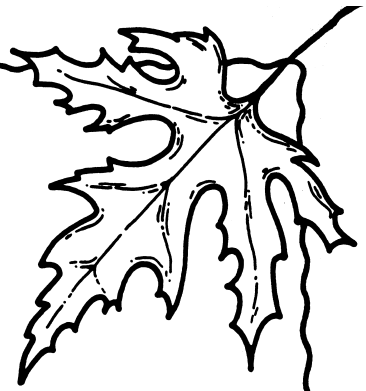

## Instructions

Here's how to unscramble this mixed up maple. Start by photocopying and giving students the individual (full-page sized) sections of the picture. They can begin to solve the Maple Mix-up by connecting the dots using a black crayon or marker. Students may have a combination upper case letters, lower case letters and numbers. Instruct the students to complete each series of dots on their page. Each student should then color in the portion of the picture on his or her section.

If you have more than 16 students, make two reprints and have one team color the picture in spring colors and the other in fall colors. To create a "spring" maple leaf, sections of the leaf labeled "A," "B" and "C" should be colored with shades of green. To create a "fall" maple leaf, the same sections may be colored with red, yellow or orange. Sections showing the seeds and stem, labeled "D," should be colored brown or tan. Small pictures of wood products may be the color of maple syrup or any color you like. Color all backgrounds blue.

Select a space on the chalkboard, bulletin board or wall that is at least 44 inches wide by 34 inches high. On a chalkboard, you may actually draw and label the entire grid pattern. On a bulletin board or wall, tape or pin the letters "A" through "D" horizontally and the numbers one through four vertically as shown.

Explain to the students how to find simple coordinates on the grid. As each of the 16 sections is completed, students should locate and tape or pin their section in the proper position. When the last section is in place, you'll see just how mixed up this maple was!

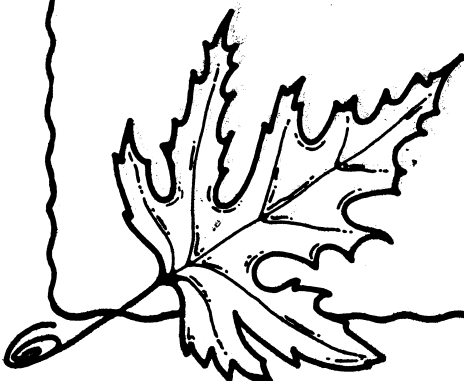
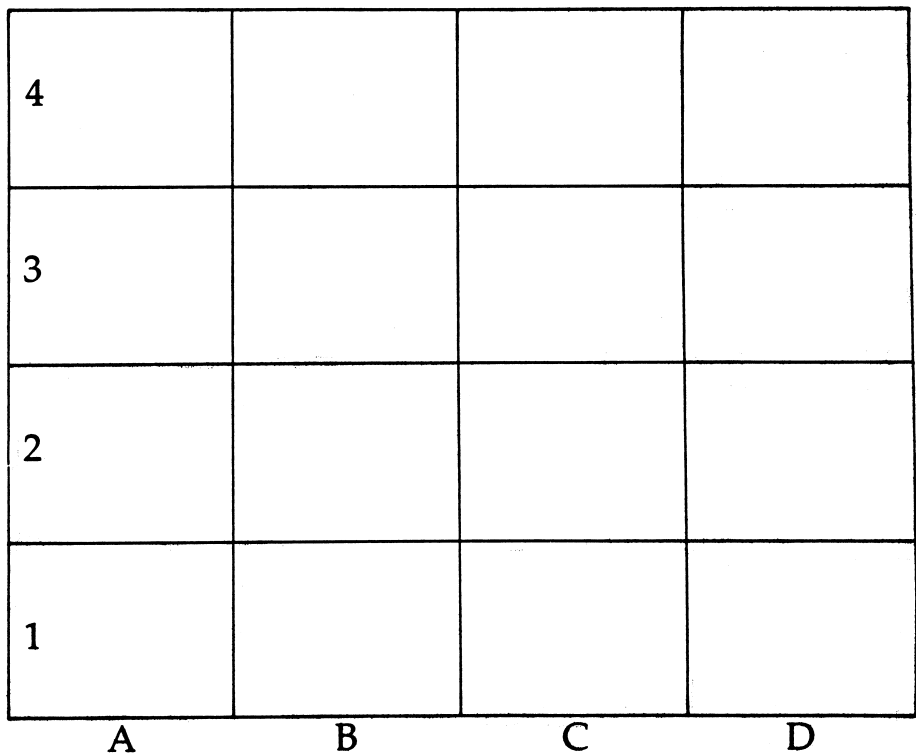
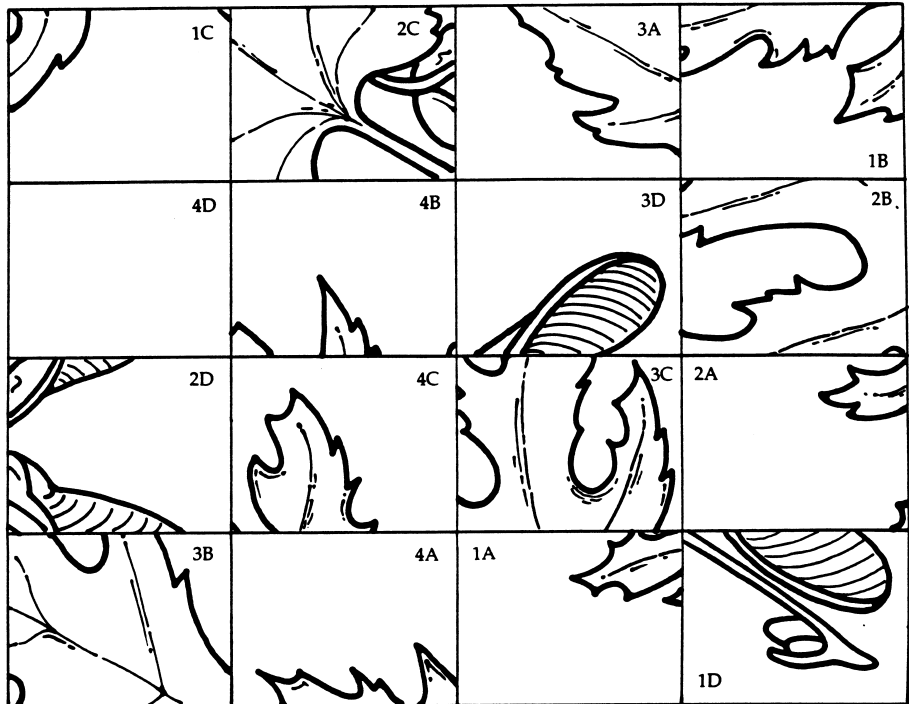

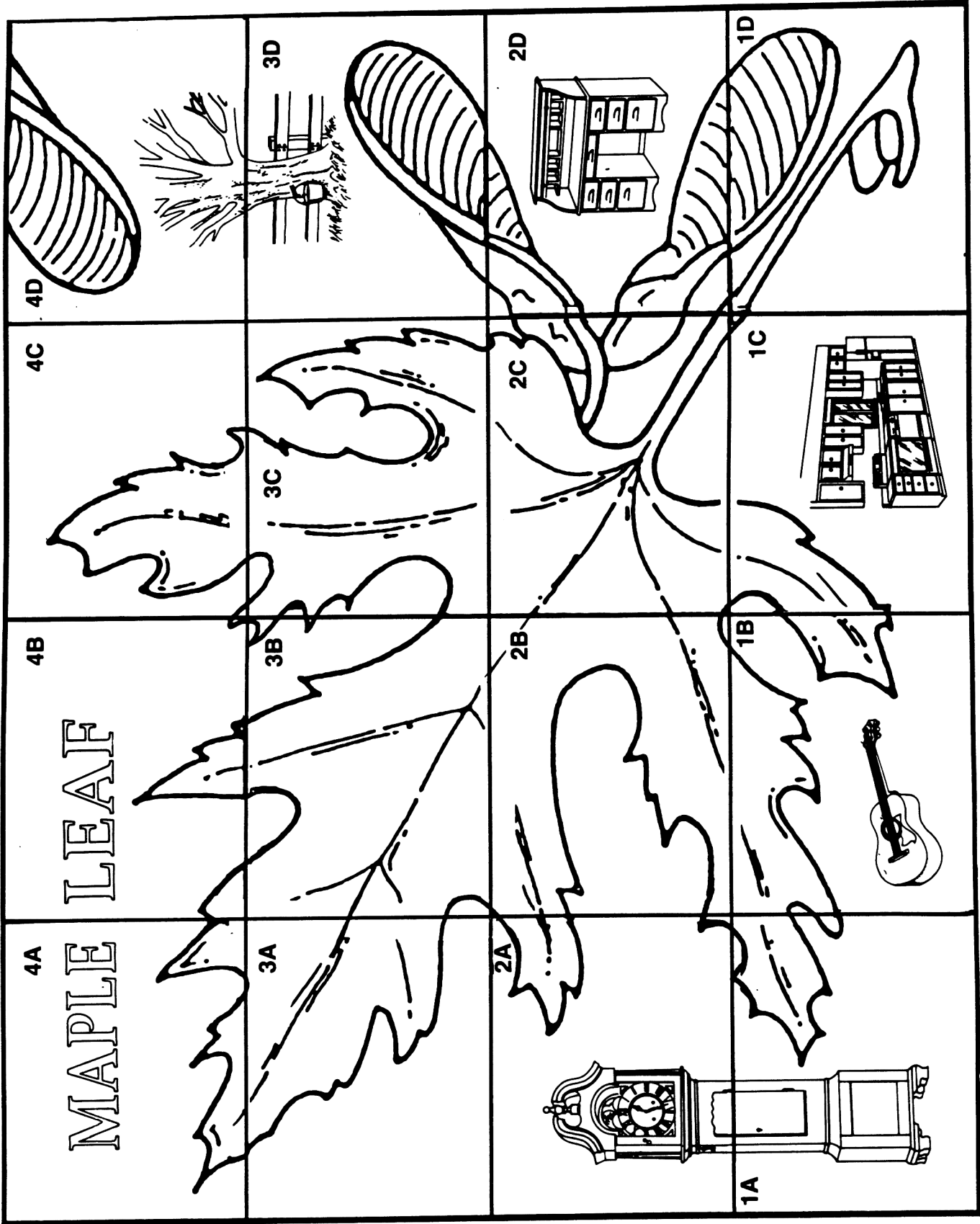

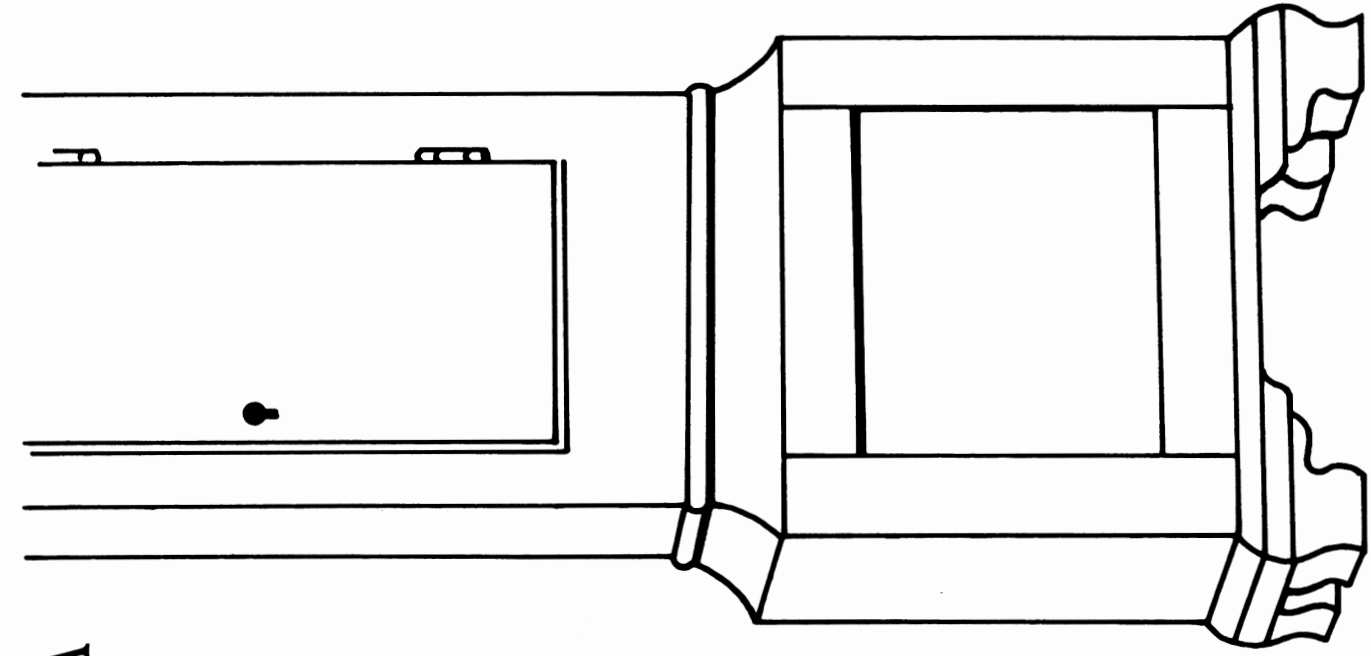

1A

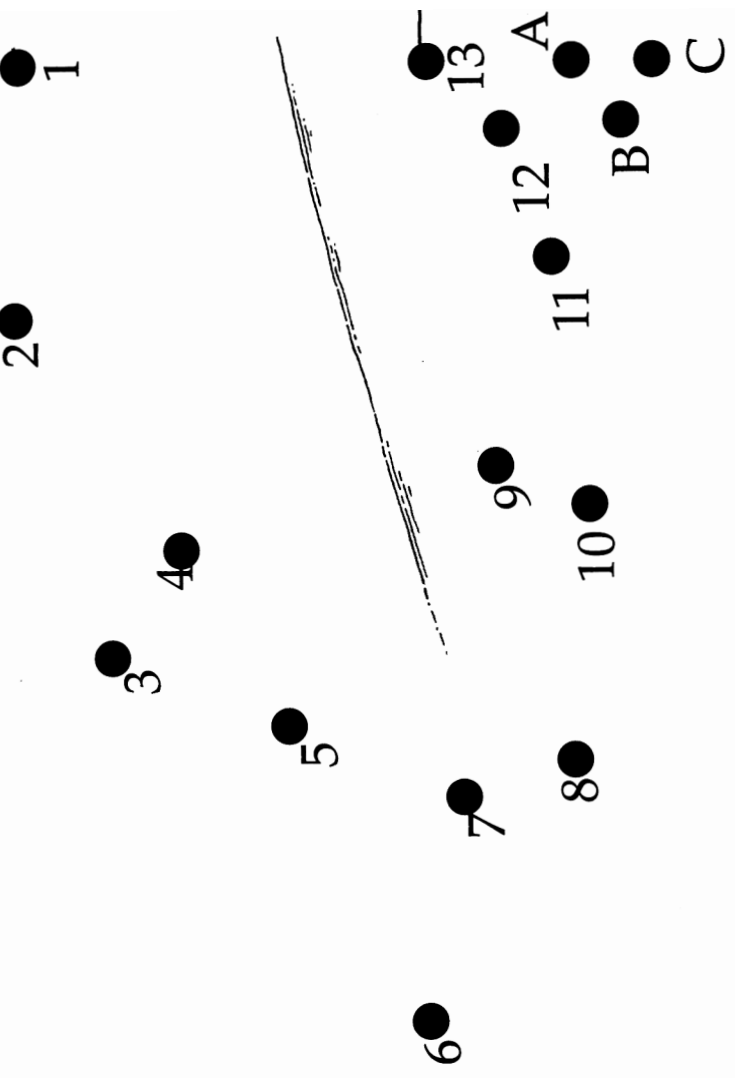

1

2

3

4

5

6

7

13

9

12

A

11

8

10

B

C

# 1B

18

17

A

H

16

B

C

D

E

F

G

14

15

12

11

13

8

9

7

10

1

2

3

4

5

6

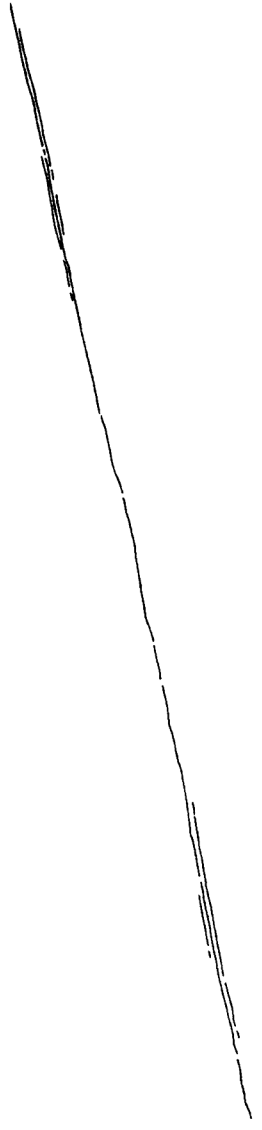
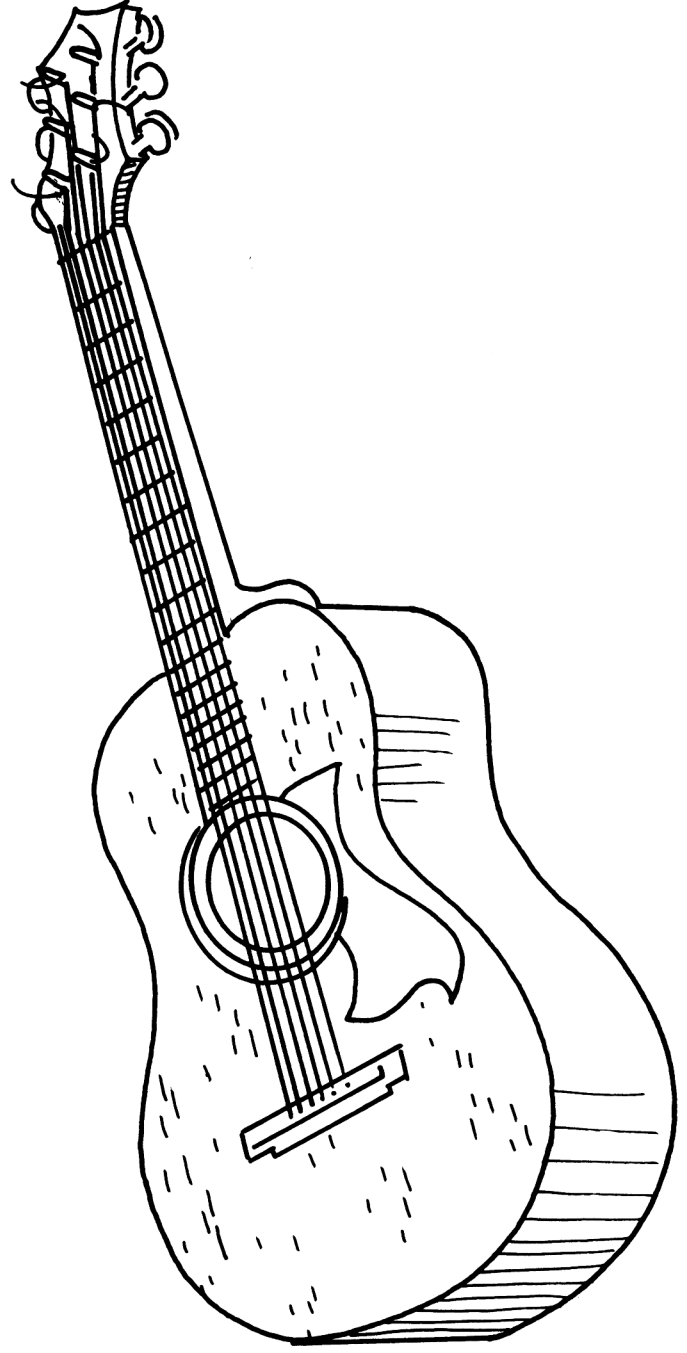

● A ● B  
● C

● D

● E

● F

1 ●  
2 ●  
3 ●

4 ●

5 ●

6 ●

7 ●

8 ●

9 ●

1C

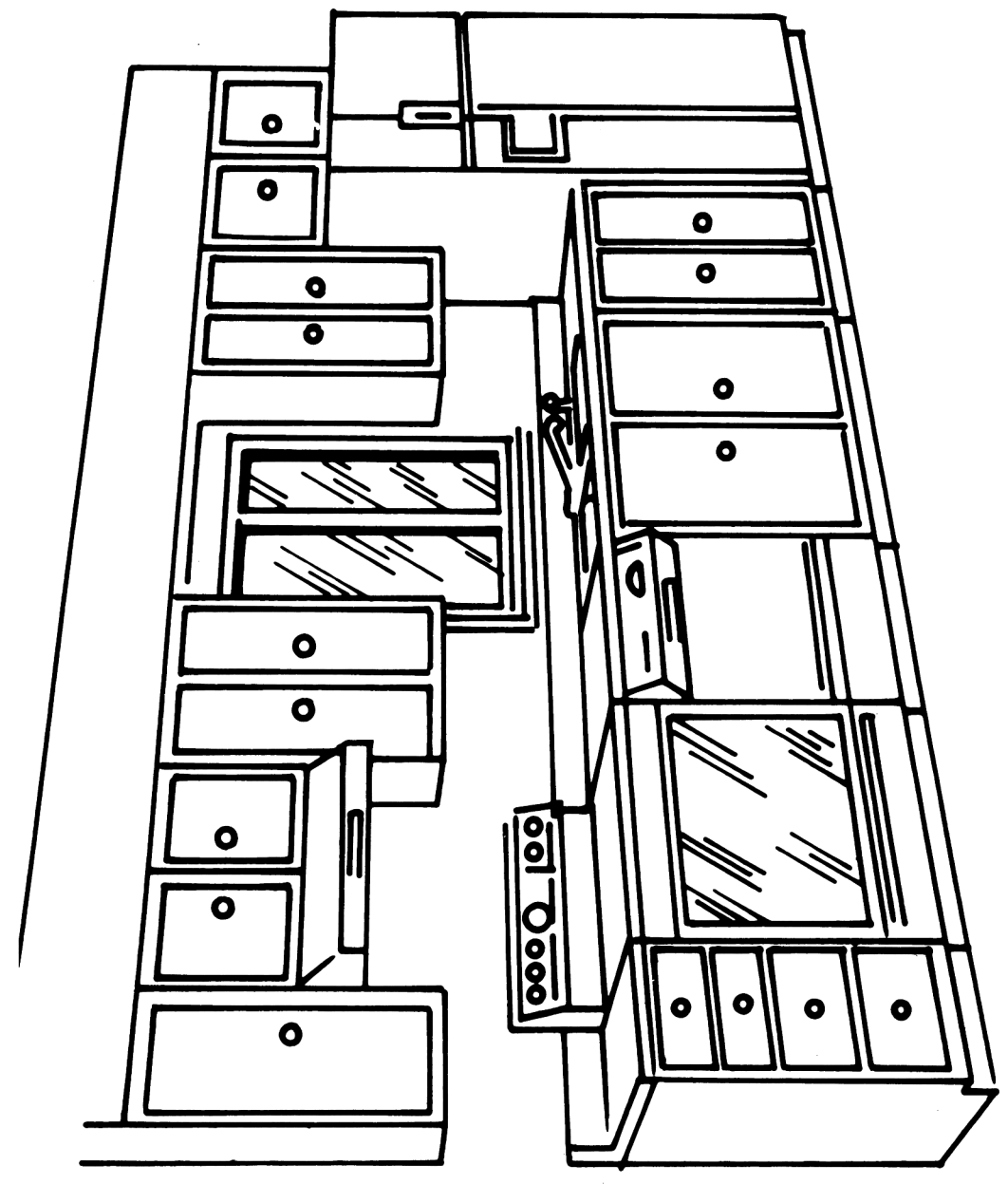

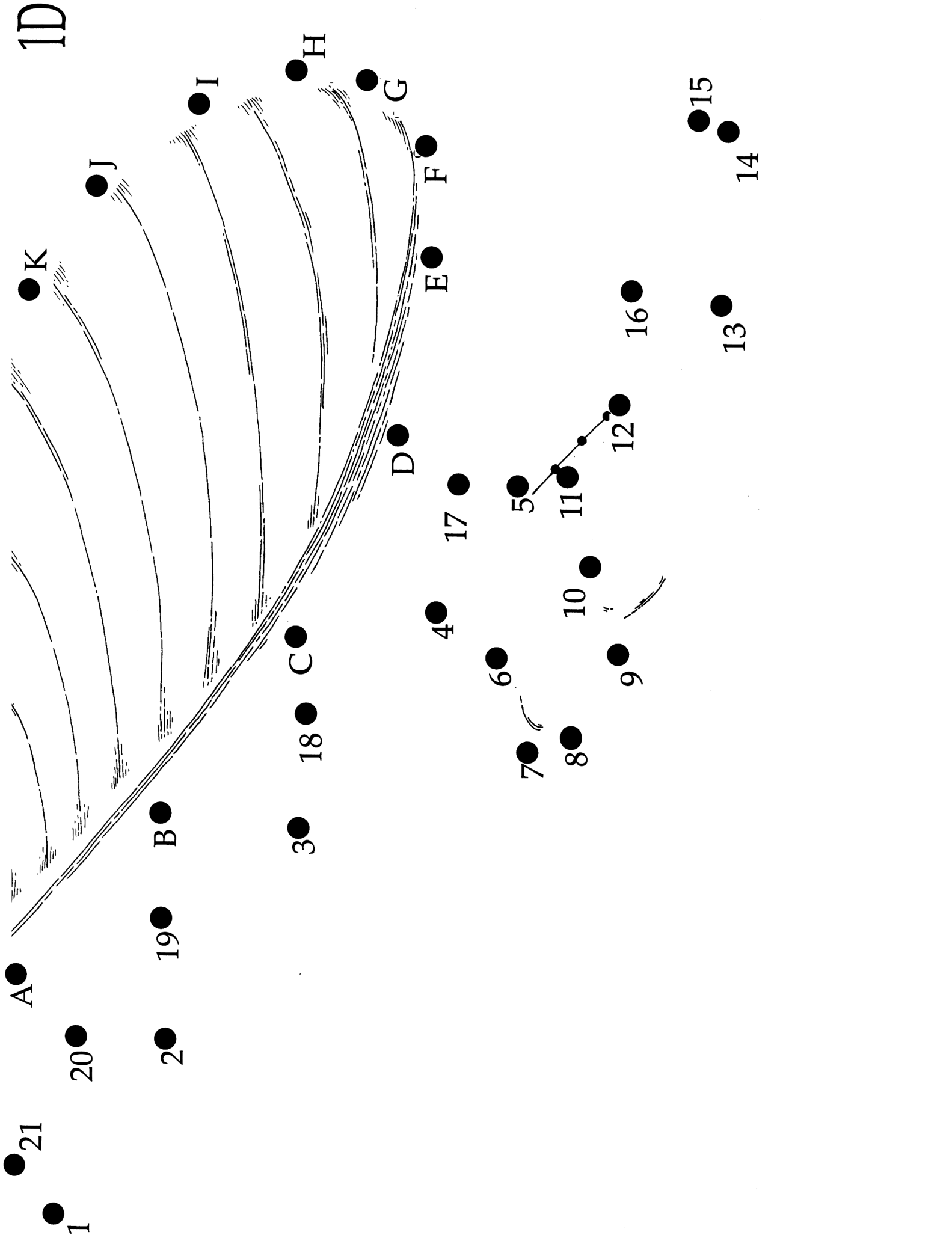



2A

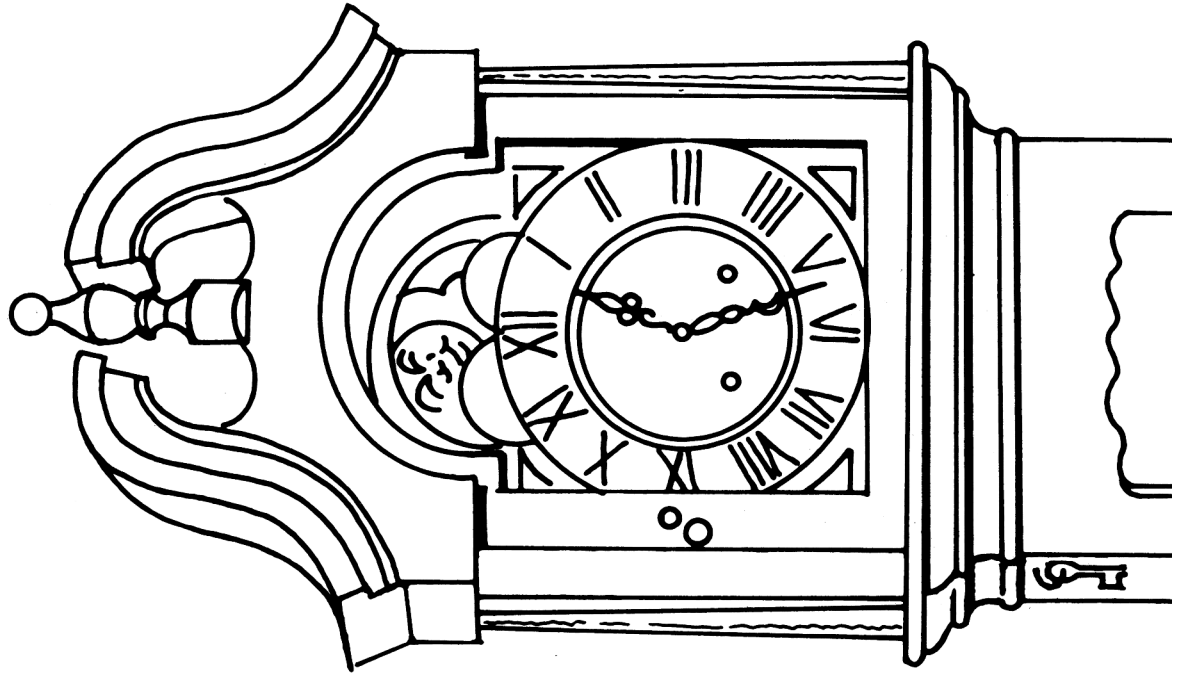

C

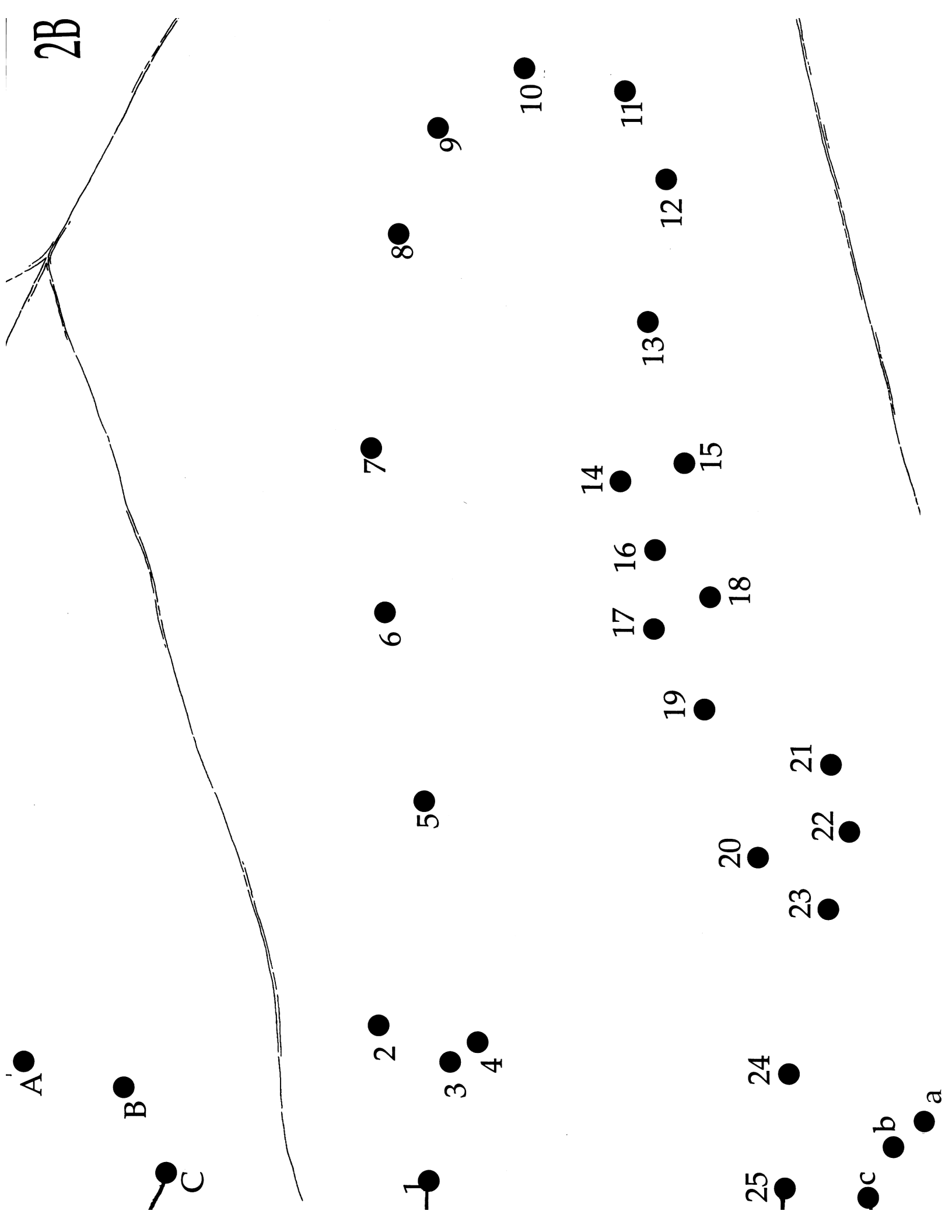

2C

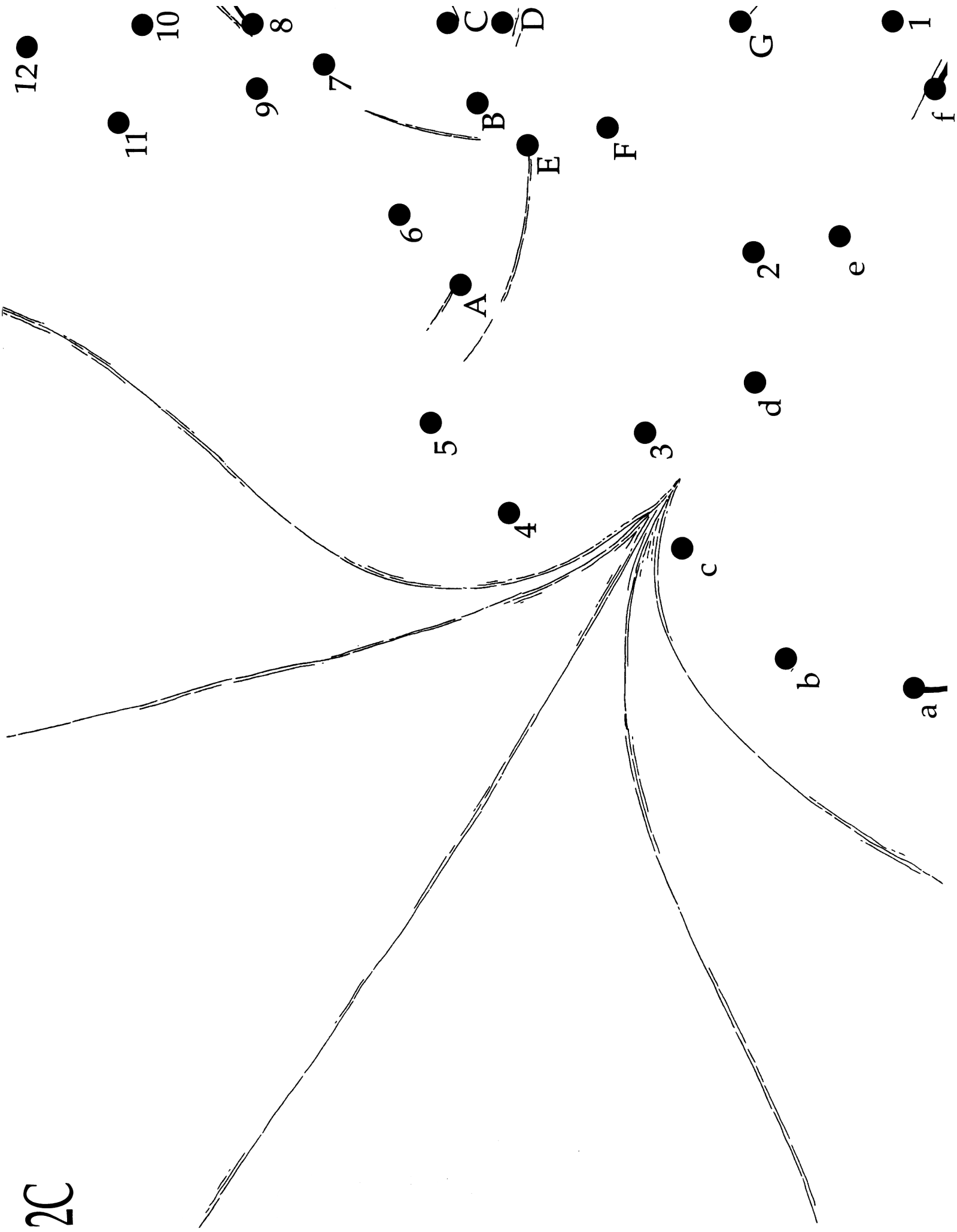

2D

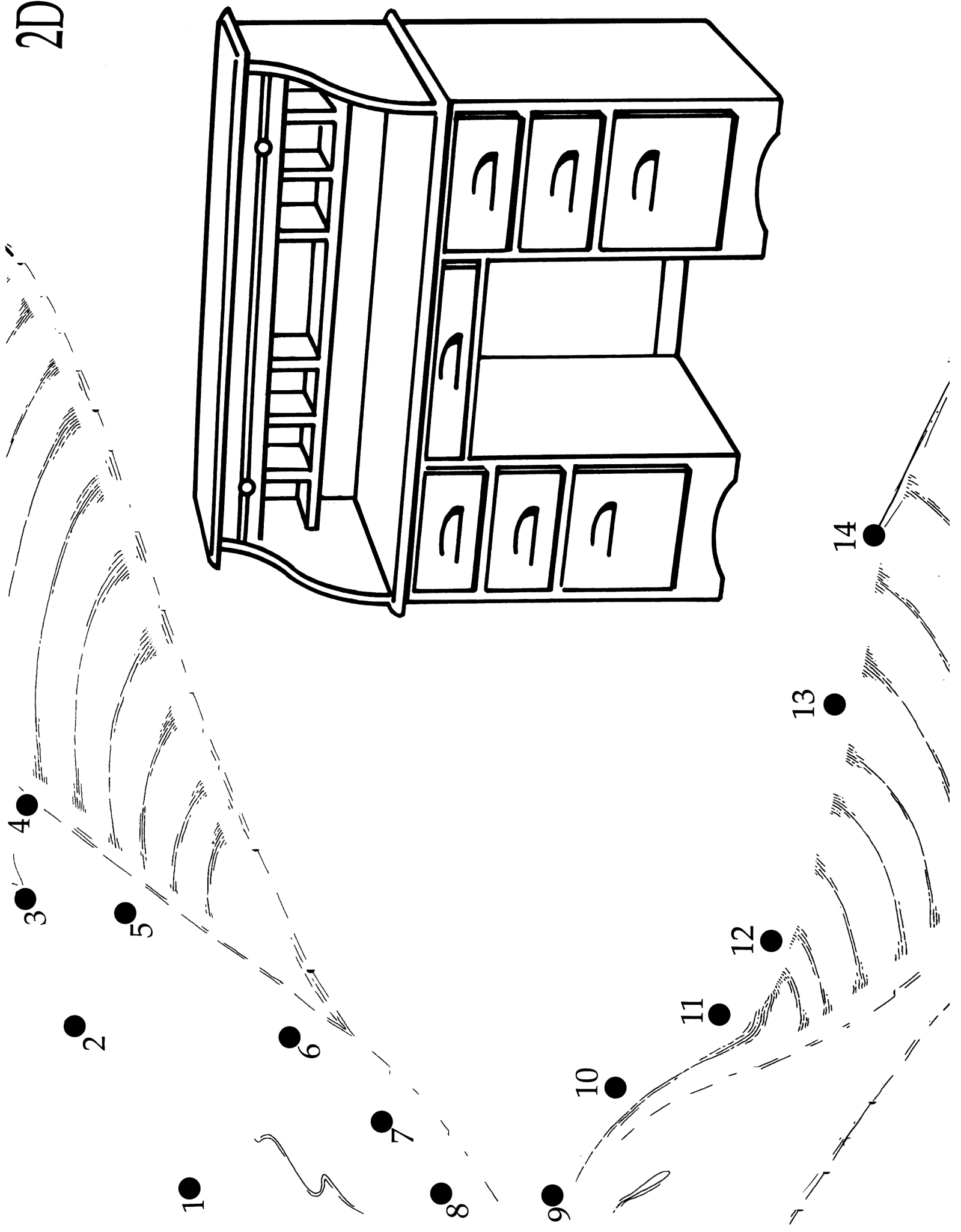

3A

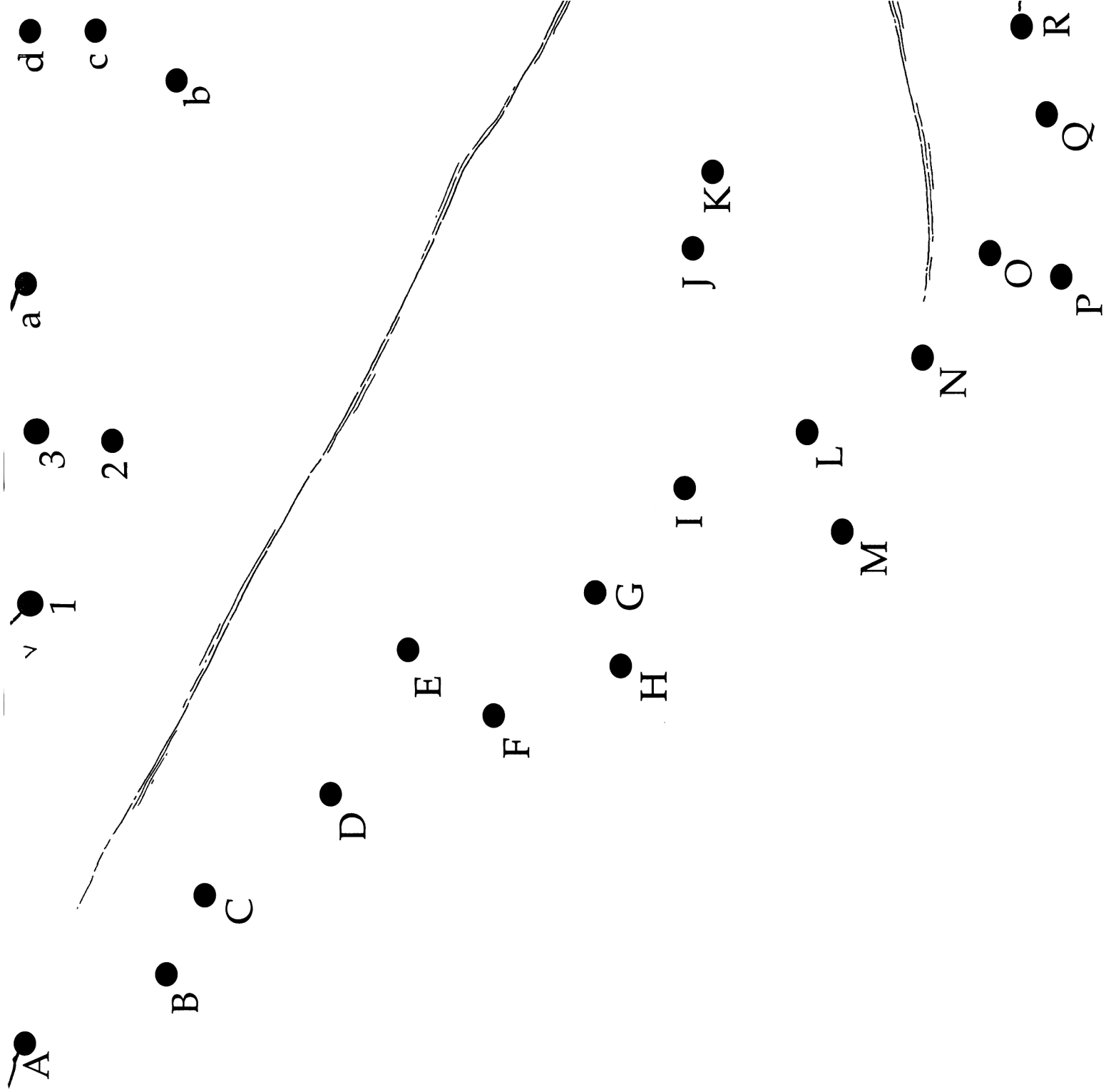

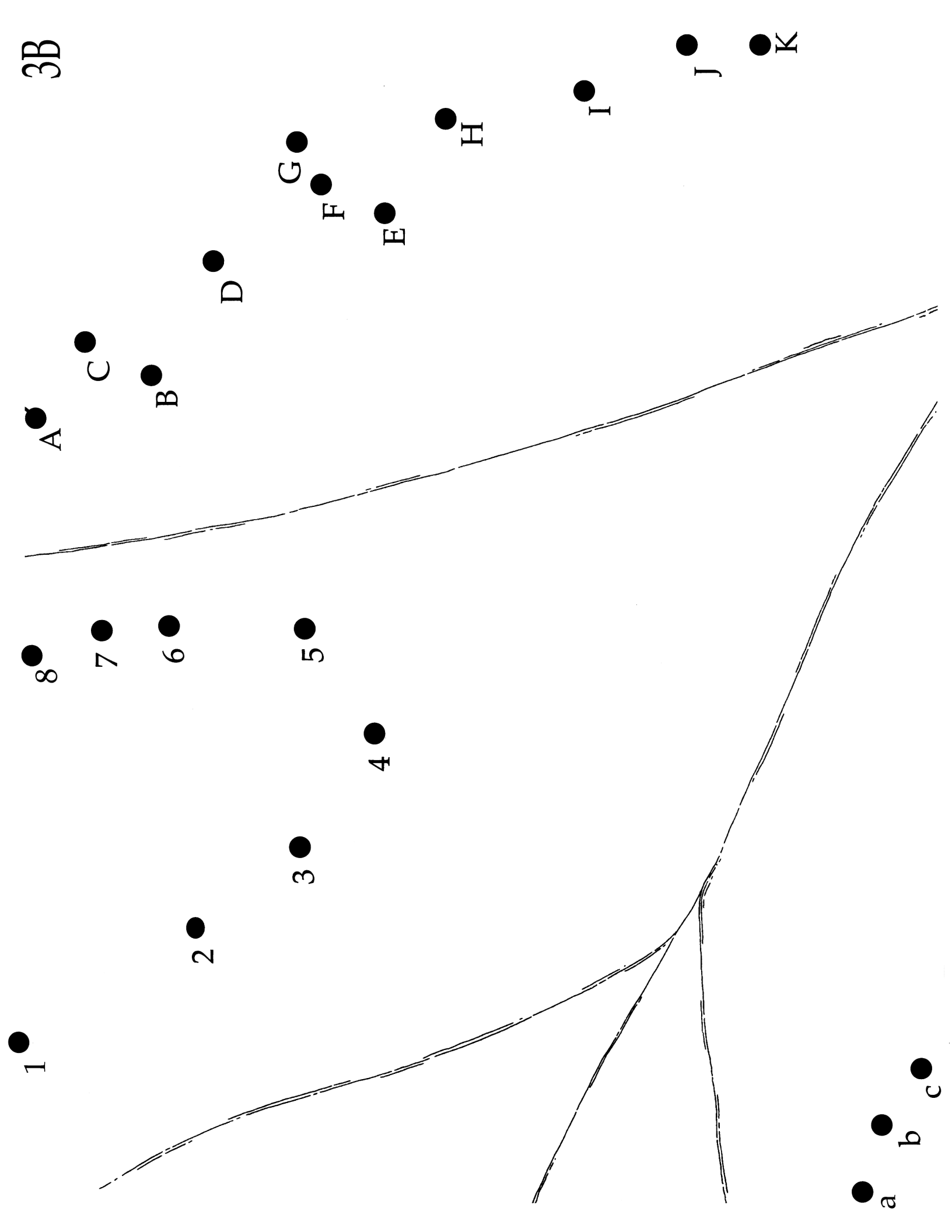

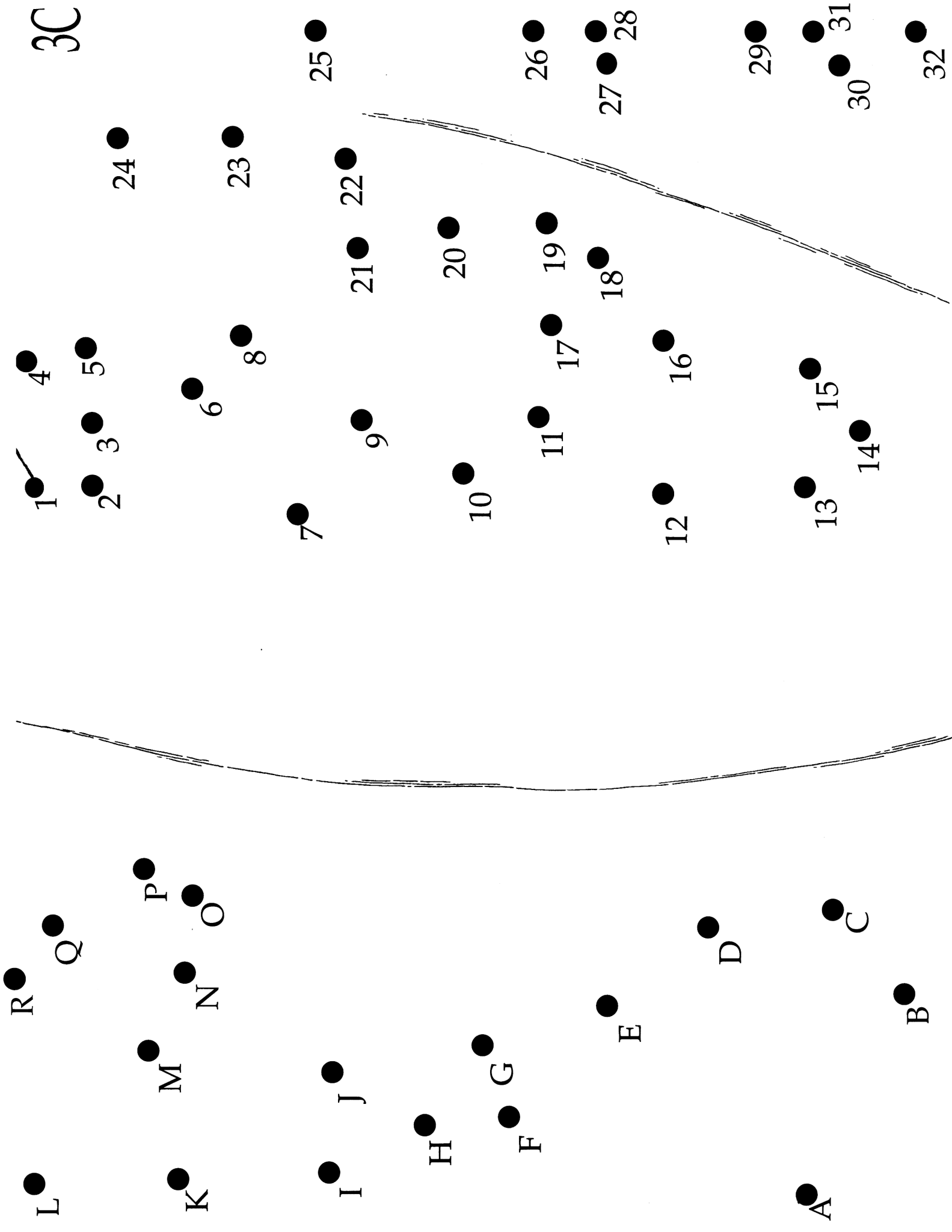

3C

3D

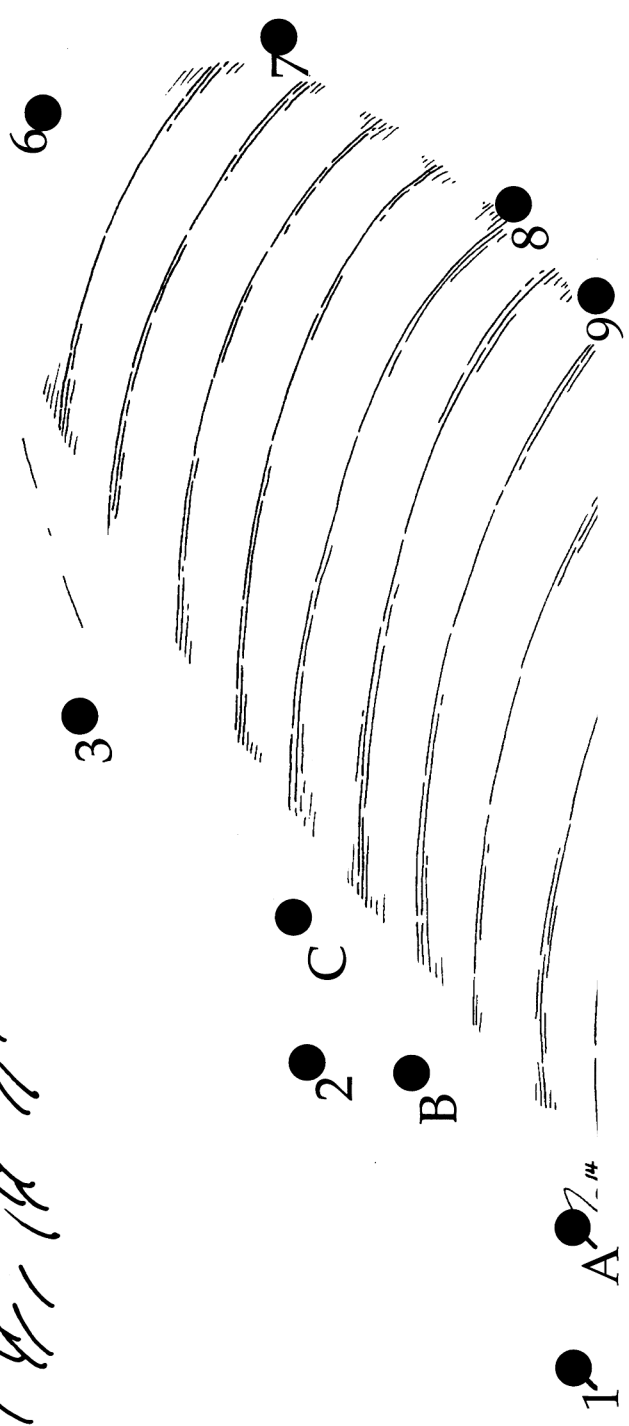
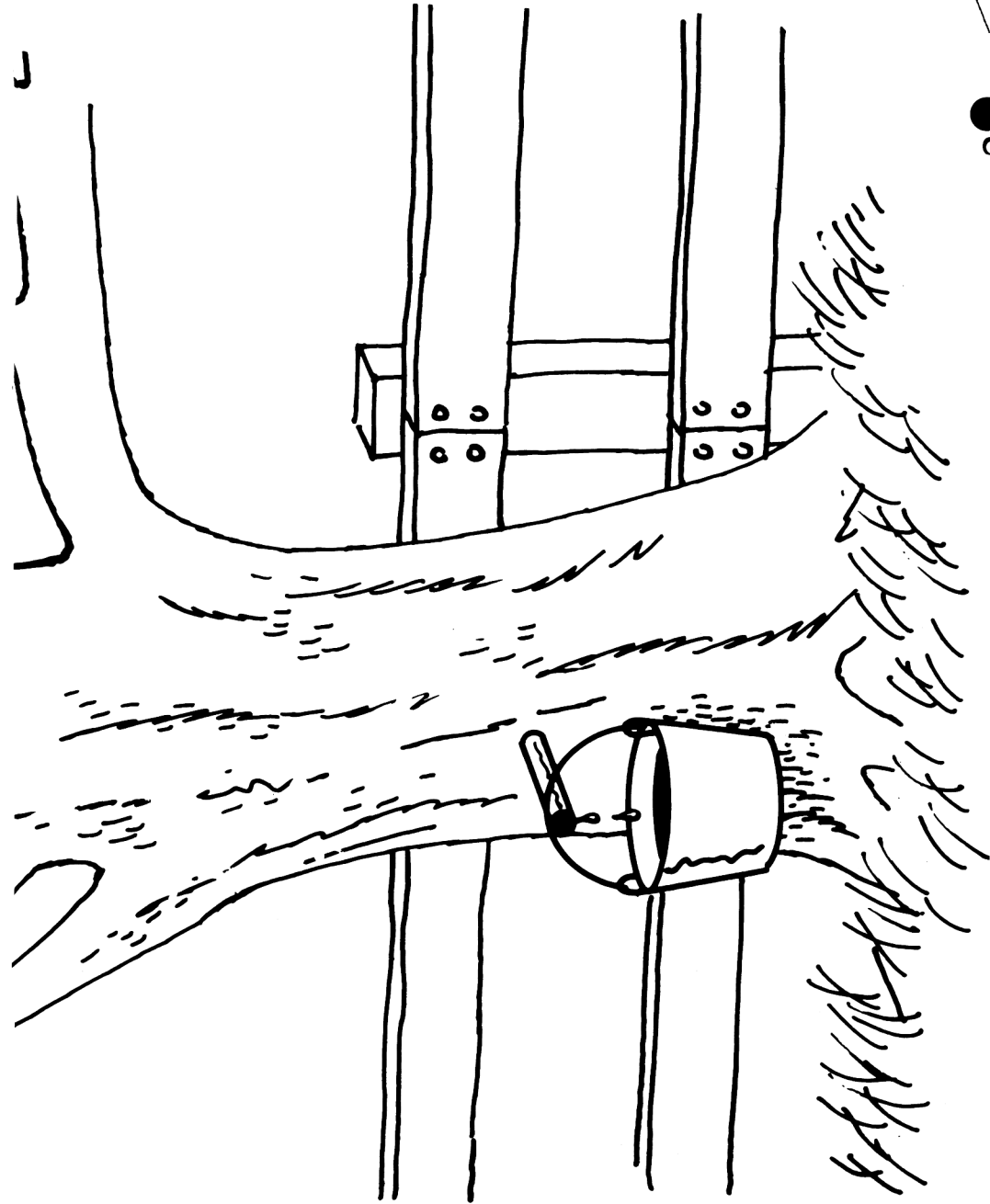

1 ● A  
2 ● B  
3 ● C



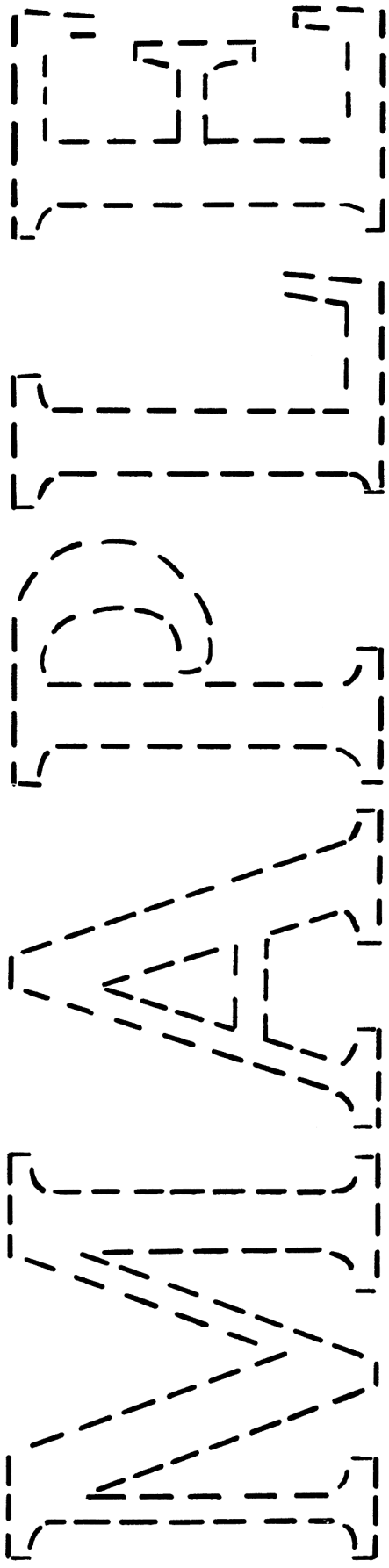

d

b

e

c

f

a

C

B

D

E

F

2

H

G

1

3

4

5

a

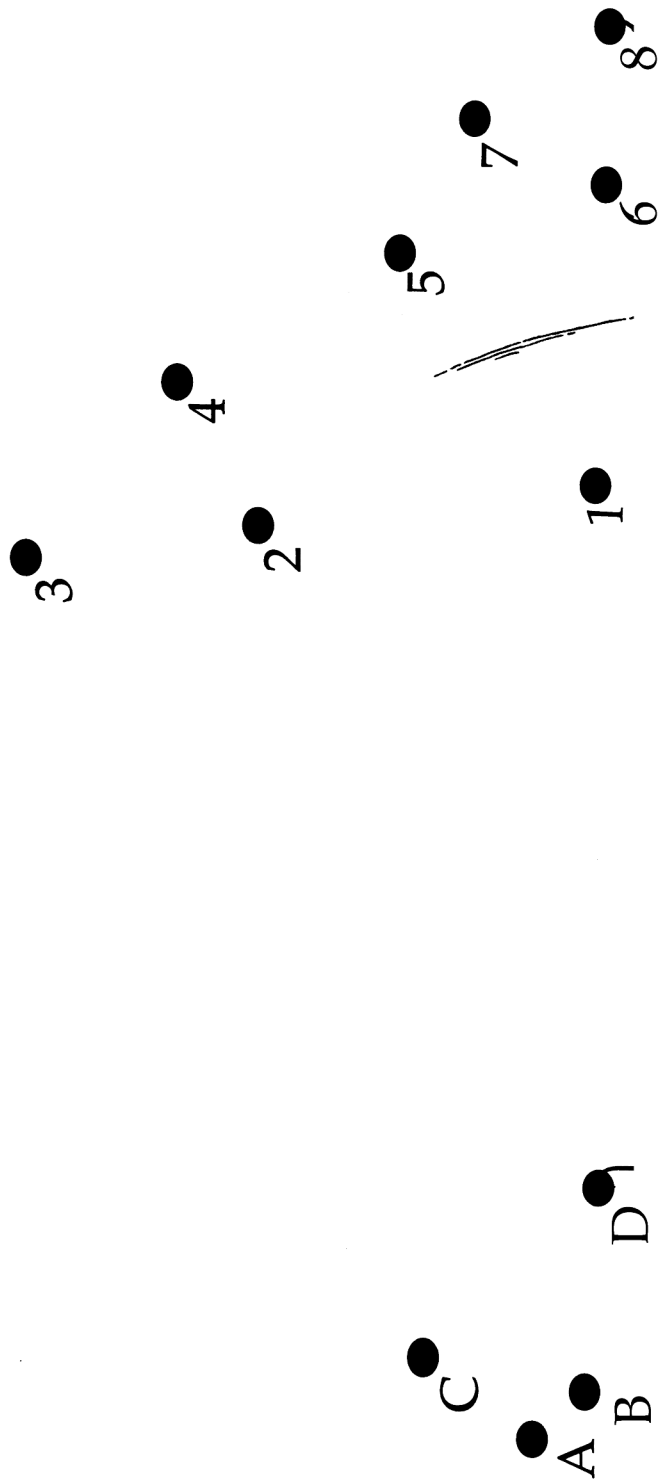
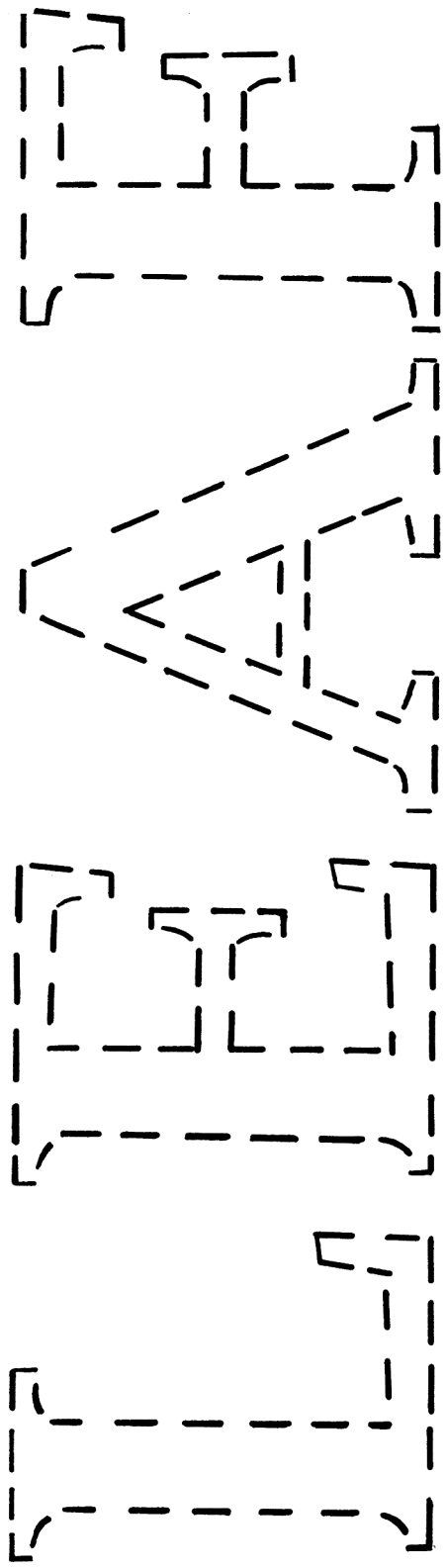

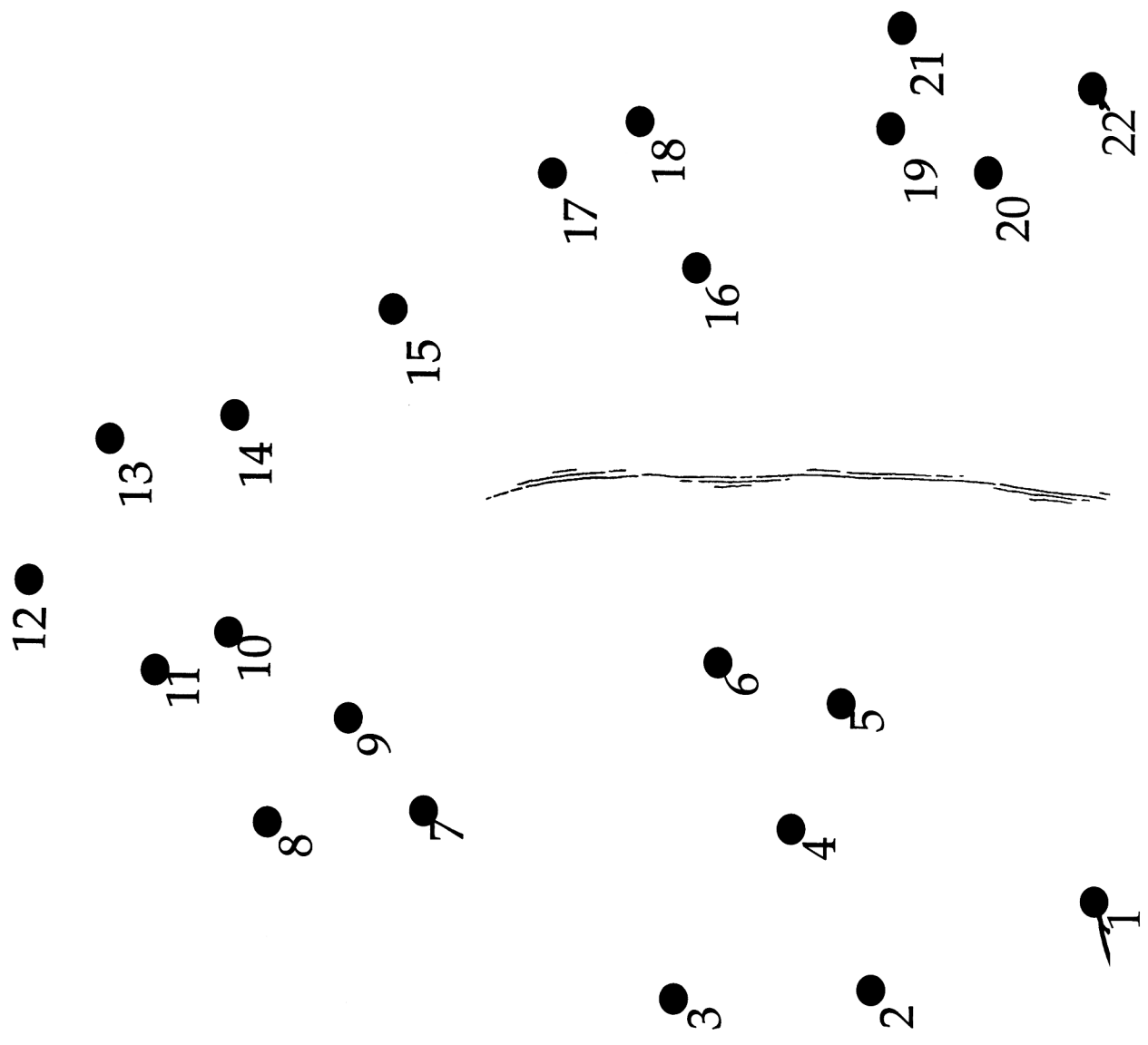

4D

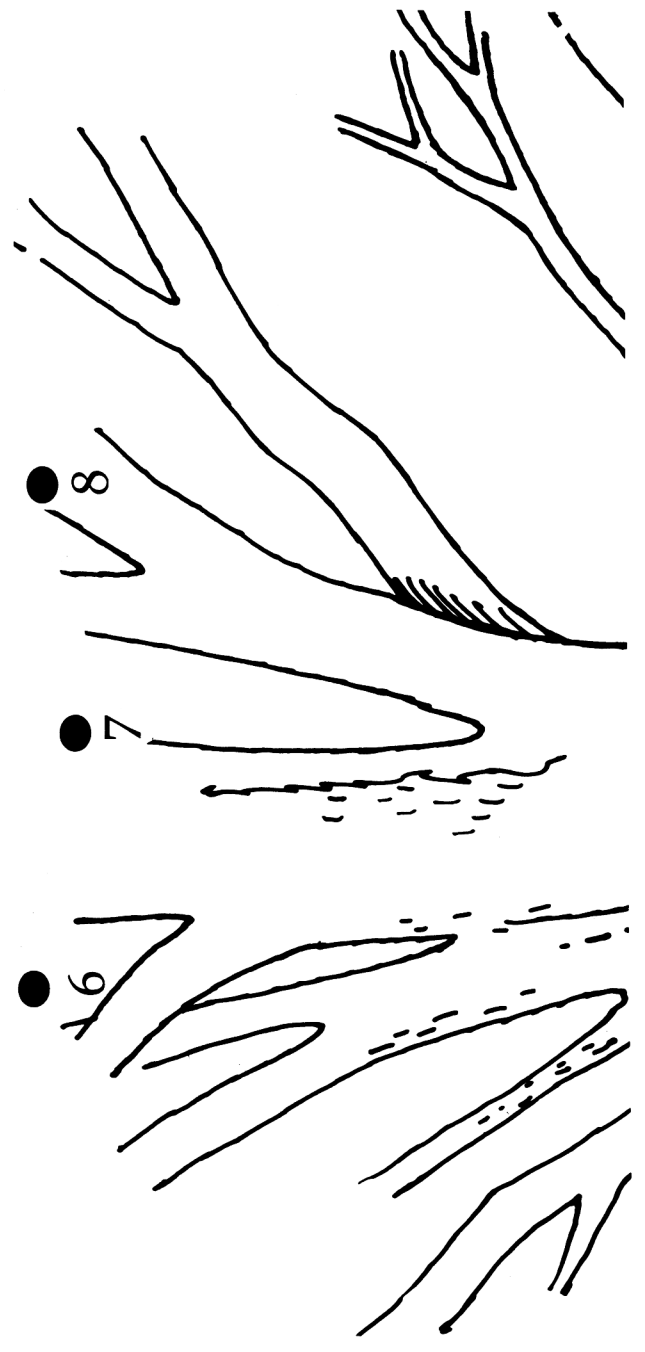
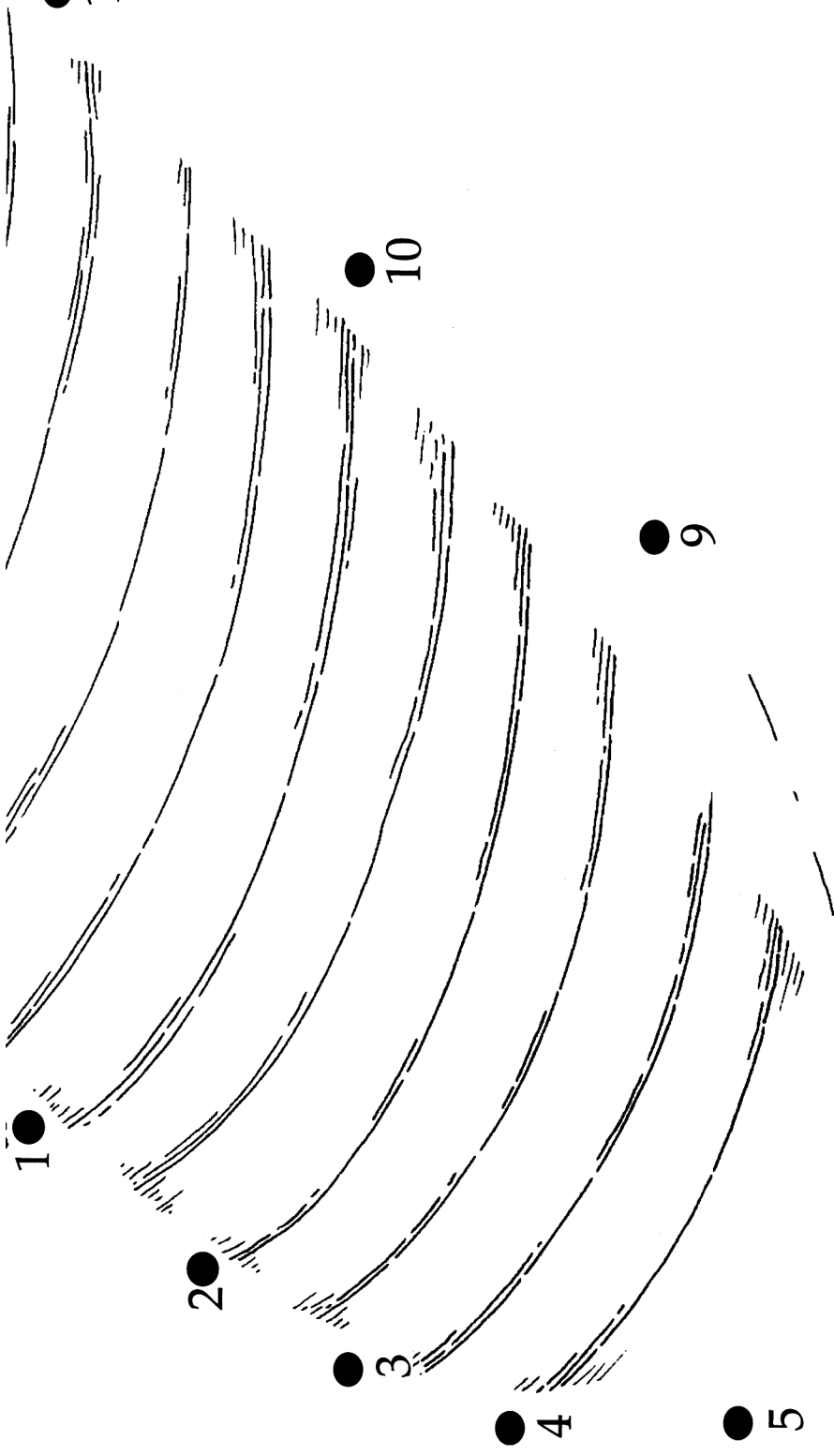

# References and Additional Sources

Consult these publications for additional information and classroom activities.

**Tekiela, Stan.** 2006. *Trees of Illinois Field Guide*. Adventure Publications, Cambridge, Minnesota. 272 pp.

**University of Wisconsin-Madison.** 1990. *Bottle Biology Resources Network*. University of Wisconsin-Madison, Madison, Wisconsin.  
<http://www.bottlebiology.org>

**Watts, May T.** 1986. *Tree Finder Nature Study Guide*. Berkeley, California. 62 pp.

**Zim, Herbert S. and A.C. Martin.** 1956. *A Golden Guide to Trees*. Golden Press, New York. 160 pp.

## Illinois Department of Natural Resources

You'll find many Illinois-specific tree-related supplemental teaching tools available from the Illinois Department of Natural Resources. Posters, activity books, activity sheets and many other items are offered. Visit the online order form at <https://dnr2.illinois.gov/teachkids/> and place your order today!



# **The Who Tree**

**Read it. Color it. Enjoy it. Share it!**

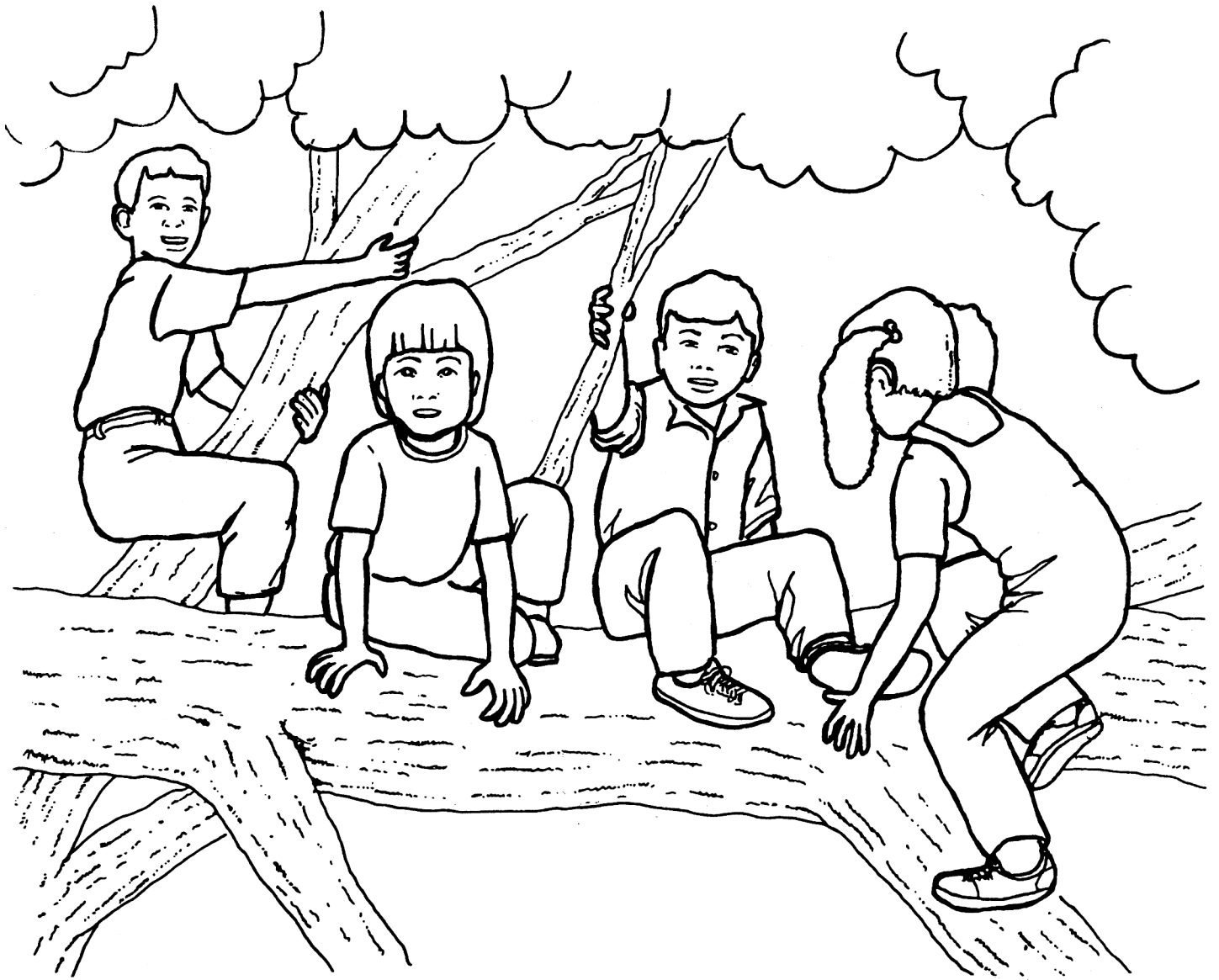

Here's why the kids from Mark Twain School made their fort in the tree. It was a big tree. The biggest tree in the little woods. The branches spread out a very long way. When you climbed it, if you found the right spot, there were so many leaves you couldn't see down.

An owl lived in the tree. Every night he would make noises. They were scary noises. No other kids would come near a tree that was this big and scary. So the kids from Mark Twain School made their fort there.

The kids were Jason, Kim, Enrique and Lucy.



Here's why the kids from Armstrong School made their playhouse under the tree. There were lots of branches lying around. They could pile them up and make rooms. The tree spread out very far. So even on the hottest day there was plenty of cool shade. The tree was so big it was easy to find. Anne and Michael liked to sit under the tree and watch the mammals and birds. Lots of mammals and birds came and went all day in the big tree. Lizzy and Nathan liked to keep the playhouse neat. They all liked to eat lunch in the playhouse. They brought sandwiches and lemonade from home.



The Armstrong kids did not like it when the Twain kids made their fort.

The Twain kids did not like it when they found Armstrong kids under their tree.

“Go away,” said the Twains.

“We were here first,” said the Armstrongs.

The Twains were mad. How can you have a fort when there are enemies under your tree?

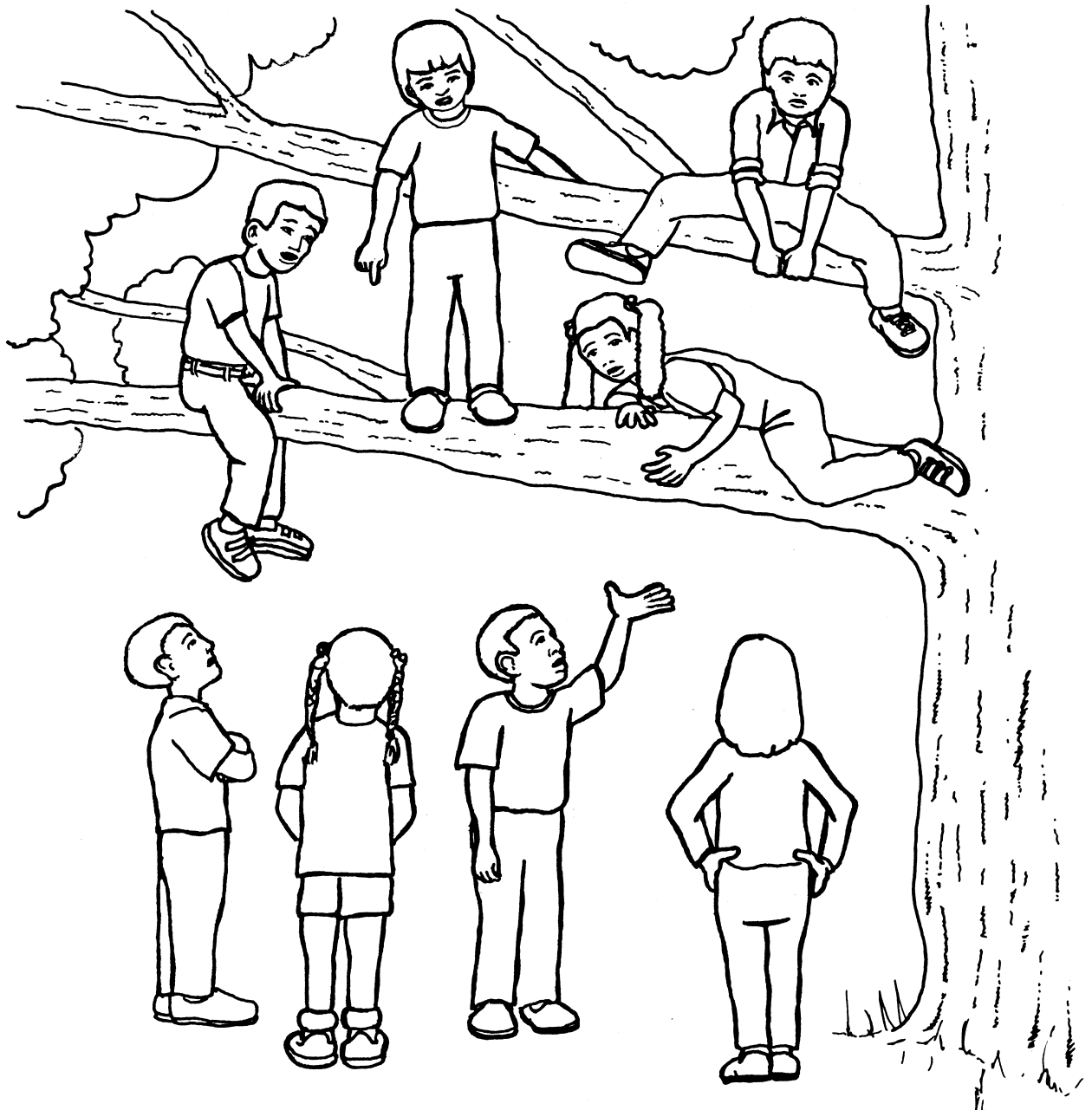

The Armstrongs were mad. How can you have a happy house with strangers in the branches?

One day, Jason yelled, "Who does this tree belong to anyway?"

"Yes, who?" asked Enrique.

"Who?" asked Michael.

"Who?" asked Lizzy and Nathan.

"Who," said a voice from above.

They all looked up, and there sat the owl.

"Who," he said.

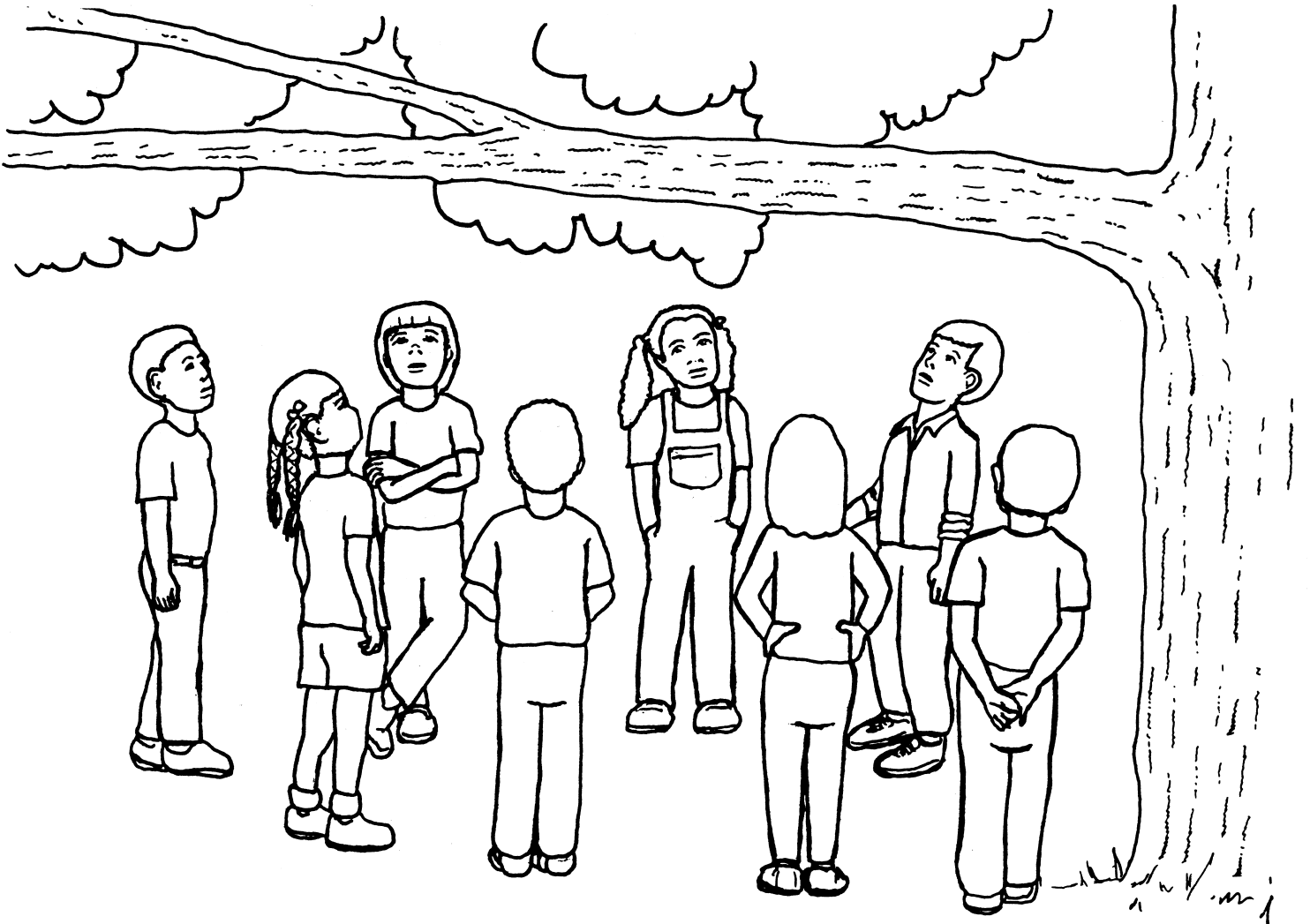

He was a big owl, as big as a cocker spaniel.

“Who,” he said again.

“Well, it’s not my tree,”  
said Jason.

“Not mine,”  
said Enrique.

“Sure not mine,”  
said Kim.

“Well, I like it,  
but it’s not my  
tree,” said Anne.

“Not mine,” said Lizzy.

“That sure is a big owl,”  
said Nathan.

“Who,” said the big owl.

“Maybe it’s the  
owl’s tree,”  
said Lucy.

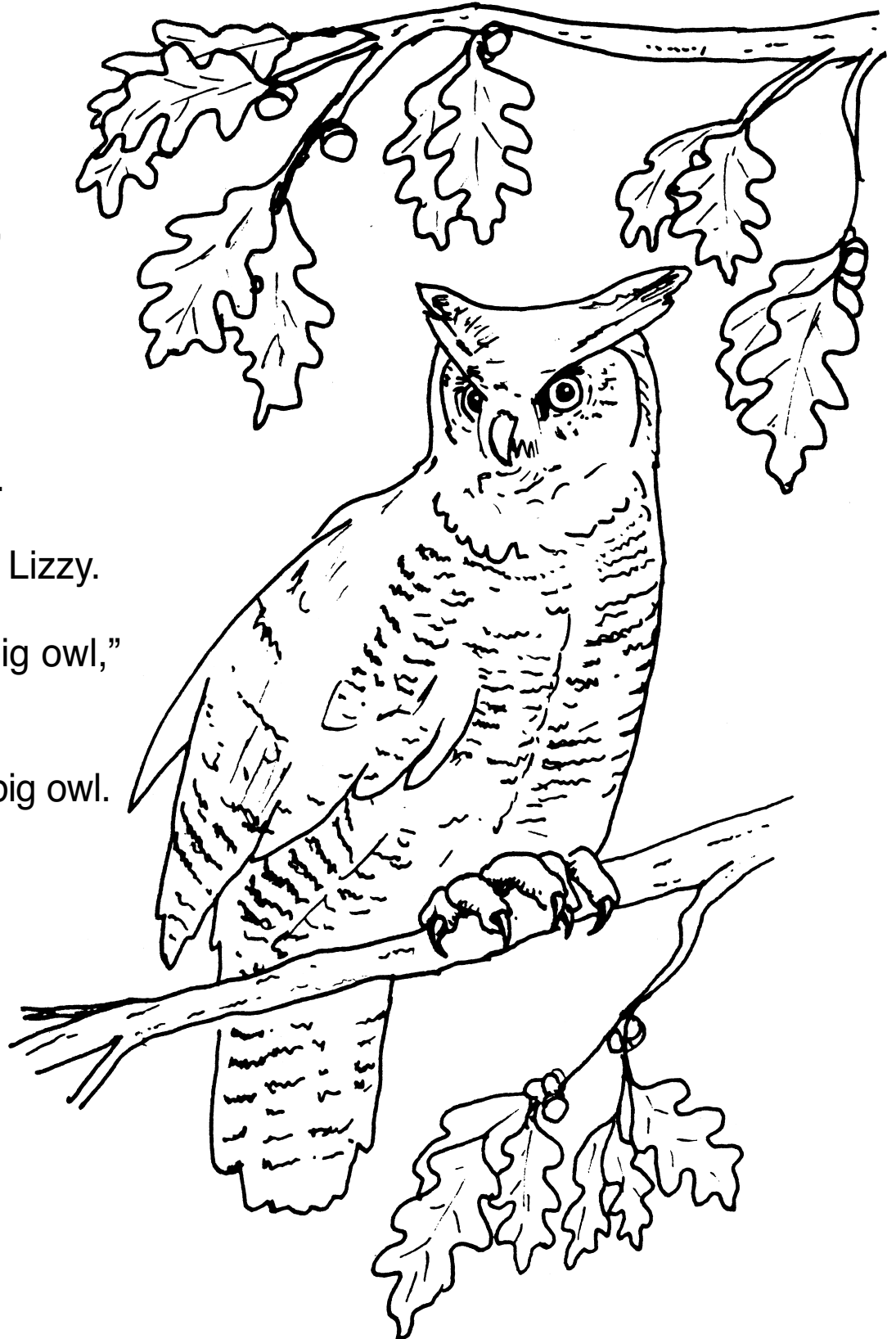



Just then, they saw a mother squirrel with two babies, jumping from branch to branch.

“Maybe it’s the squirrel’s tree,” said Michael.

A blue jay made a very loud noise trying to scare the squirrels.

“I know. It’s the blue jay’s tree,” said Enrique.

“Who,” said the owl.

Then Lizzy said, “If all of these animals can share the tree, why can’t we?”

And that’s just what they did.



The kids from Mark Twain School had their fort. Every once in a while, they would invite the kids from Armstrong School to climb up and see the view—and to hear about their adventures.

The kids from Armstrong School had their house. Every once in a while, they would invite the Twain kids to lunch. They would bring extra sandwiches and lemonade.

All summer they shared the tree. And watched the baby squirrels grow up.

In the fall when the leaves came down, they could see the big owl better than ever.

“Who would ever argue about such a beautiful tree?” said Jason.

“Who?” asked Anne.

“Who,” said the big owl.

